

IDRES4D

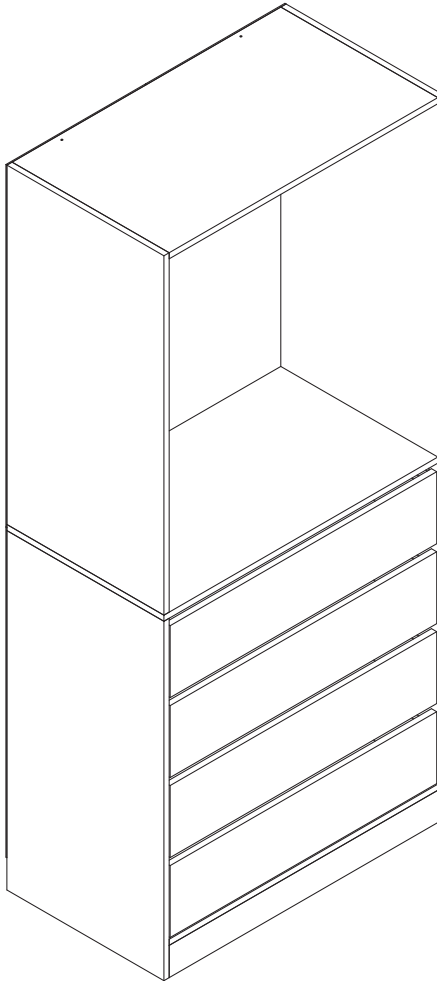

FRANÇAIS

Conseils d'entretien.....	6
Conseils d'utilisation.....	7
Avertissements.....	8
Garantie.....	9
Montage.....	10

**IMPORTANT, À CONSERVER
POUR CONSULTATION ULTÉRIEURE :
À LIRE ATTENTIVEMENT**

ESPAÑOL

Instrucciones de mantenimiento.....	6
Instrucciones de uso.....	7
Advertencia.....	8
Garantía.....	9
Montaje.....	10

**IMPORTANTE, CONSÉRVELO
PARA FUTURAS REFERENCIAS:
LEA ATENTAMENTE**

ENGLISH

Directions for use.....	6
Directions for use.....	7
Warning.....	8
Warranty.....	9
Assembly.....	10

**IMPORTANT, RETAIN FOR FUTURE
REFERENCE: PLEASE READ
CAREFULLY**

NEDERLANDS

Onderhoud.....	6
Gebruiksaanwijzingen	7
Waarschuwingen	8
Garantie.....	9
Montage.....	10

**BELANGRIJK, BEWAAR VOOR
TOEKOMSTIGE REFERENTIE:
ZORGVULDIG LEZEN**

PORTUGUÊS

Instruções para manutenção	6
Instruções de utilização	7
Advertência.....	8
Garantia.....	9
Assembleia.....	10

**IMPORTANTE, CONSERVE A
REFERÊNCIA DA FATURA:
LEIA CUIDADOSAMENTE**

ITALIANO

Consigli per la manutenzione	6
Consigli per l'uso	7
Avvertenze.....	8
Garanzia.....	9
Montaggio.....	10

**IMPORTANTE, CONSERVARE PER
ULTERIORI CONSULTAZIONI:
LEGGERE ATTENTAMENTE**

DEUTSCH

Pflegehinweis	6
Anwendungs	7
Warnhinweise	8
Garantie	9
Montage	10

**WICHTIG, FÜR SPÄTEREN
GEBRAUCH AUFBEWAHREN:
AUFMERKSAM LESEN**



Garantie : 2 ans
Garantía : 2 años
Warranty: 2 years
Garantie: 2 jaar
Garantia: 2 anos
Garanzia : 2 anni
Garantie: 2 Jahre



Destiné à un usage domestique
Destinado a un uso doméstico
For domestic use only
Bestemd voor huishoudelijk gebruik
Para uso doméstico
Destinato ad un uso domestico
Für den Haushaltsgebrauch vorgesehen



Attention : risques de blessures
Cuidado : riesgo de lesión
Warning : risk of injuries
Waarschuwing: risico op verwondigen
Cuidado: risco de ferimentos
Attenzione : rischio infortunio
Warnung: Verletzungsgefahr



Poids maximal : 50 kg
Peso máximo : 50 kg
Maximum weight: 50 kg
Maximale gewicht: 50 kg
Peso máximo: 50 kg
Peso massimo: 50 kg
Maximales gewicht: 50 kg

CONSEILS D'ENTRETIEN / INSTRUCCIONES DE MANTENIMIENTO / DIRECTIONS FOR USE / ONDERHOUD / INSTRUÇÕES DE UTILIZAÇÃO / CONSIGLI PER LA MANUTENZIONE / PFLEGEHINWELS

FR

Dépoussiérer régulièrement avec un chiffon propre, doux et sec.
Proscrire tout abrasif et produits acides. Ne jamais employer de solvants.

ES

Quitar el polvo regularmente con un paño limpio, suave y seco.
No utilice productos abrasivos o ácidos. No utilice nunca disolventes de limpieza.

EN

Regularly dust with a clean, soft and dry cloth.
Do not use any abrasive or acidic products. Never use cleaning solvents.

NL

Stof regelmatig af met een schone, zachte en droge doek.
Sluit alle schurende en zure producten uit. Gebruik nooit oplosmiddelen

PT

Pó regularmente com um espanador limpo, macio e seco.
Proibir qualquer esfregão e produtos ácidos. Nunca utilizar solvente de limpeza.

IT

Spolverare regolarmente con un panno pulito, morbido e asciutto.
Non usare prodotti abrasivi o acidi. Non usare mai solventi.

DE

Regelmäßig mit einem sauberen, weichen und trockenen Tuch abstauben.
Keinesfalls abrasive und ätzende Reinigungsprodukte anwenden. Verwenden Sie niemals Lösungsmittel.

CONSEILS D'UTILISATION / INSTRUCCIONES DE USO / DIRECTIONS FOR USE / GEBRUIKSIINSTRUCTIES / INSTRUÇÕES DE UTILIZAÇÃO / CONSIGLI PER L'USO / ANWENDUNGS

FR

Pour des raisons de stabilité, et afin de préserver les pas et les vis d'un serrage de travers, impératif d'assembler manuellement tous les éléments, et de serrer toutes les vis à la main dans un premier temps. Une fois l'assemblage terminé, vous pouvez procéder au serrage de la visserie de manière plus ferme.

Attention, ne pas s'asseoir sur le produit. En effet, cela peut entraîner une dégradation du produit, voire des blessures, n'entrant pas dans le cadre de la garantie.

ES

Para garantizar la estabilidad y evitar que las roscas de los tornillos se deformen, es imprescindible empezar por montar y atornillar cada pieza a mano. Una vez completado el montaje, se puede proceder a apretar los tornillos con mayor firmeza.

No se siente sobre el producto. De lo contrario, el producto podría resultar dañado o incluso sufrir lesiones, lo que no está cubierto por la garantía.

EN

To ensure stability and in order to prevent the screw threads from becoming deformed, it is essential to start by assembling and screwing in each piece by hand. Once the assembly is complete, you can proceed to tighten the screws more firmly.

Do not sit on the product. Doing so may result in damage to the product or even injury, which is not covered by the warranty.

NL

Omwille van de stabiliteit en om doordraaien te voorkomen, is het van cruciaal belang om alle elementen handmatig te monteren en alle schroeven in eerste instantie met de hand aan te halen. Na de montage kunt u de schroeven steviger vastzetten.

Ga niet op het product zitten. Dit kan leiden tot schade aan het product of zelfs letsel, wat niet onder de garantie valt.

PT

Por razões de estabilidade e a fim de preservar o alinhamento da estrutura, é imperativo montar cada peça à mão em primeiro lugar. Uma vez terminada a montagem, é possível proceder ao aperto firme do parafuso.

Não se sentar sobre o produto. Fazê-lo pode resultar em danos no produto ou mesmo em ferimentos, que não estão cobertos pela garantia.

IT

Per ragioni di stabilità e per proteggere le filettature delle viti da un errato serraggio, è imperativo assemblare tutti gli elementi a mano e stringere tutte le viti a mano all'inizio. Una volta completato il montaggio, le viti possono essere serrate più saldamente.

Non sedersi sul prodotto. Ciò potrebbe causare danni al prodotto o addirittura lesioni, che non sono coperte dalla garanzia.

DE

Aus Stabilitätsgründen und um ein Überziehen der Gewinde zu verhindern, müssen unbedingt alle Komponenten manuell zusammengebaut und alle Schrauben zuerst von Hand angezogen werden. Sobald die Montage abgeschlossen ist, können Sie die Hardware fester anziehen.

Setzen Sie sich nicht auf das Produkt. Dies kann nämlich zu einer Beschädigung des Produkts oder sogar zu Verletzungen führen, die nicht unter die Garantie fallen.

AVERTISSEMENTS / WAARSCHUWINGEN / WARNHINWEISE / WARNING / ADVERTENCIA / ADVERTÊNCIA / AVVERTENZE

FR

ATTENTION : Risque de blessure grave ou mortelle en cas de basculement du meuble. Pour éviter que le meuble ne bascule, il faut le fixer au mur de façon permanente à l'aide des pièces incluses pour la fixation. Les vis et chevilles ne sont pas incluses car leur choix dépend du matériau du mur sur lequel est fixé le meuble. Utilisez des vis et chevilles adaptées au matériau du mur.

ES

PRECAUCIÓN: Riesgo de lesiones mortales o graves en caso de que el mueble se vuelque. Para evitar que el mueble se caiga, debe fijarlo a la pared de forma permanente con las piezas de fijación incluidas. Los tornillos y tacos no están incluidos, ya que la selección de estas piezas depende del material de la pared en la que se fijará el mueble. Utilice los tornillos y tacos adecuados para el material de su pared.

EN

Caution: Risk of mortal or serious injuries in case of the furniture toppling over. To avoid the furniture falling, you must fix it to the wall permanently with the included fixing pieces. Screws and dowels are not included, as the selection of these parts is dependent on the wall material that the furniture will be fixed to. Use the correct screws and dowels for your wall material.

NL

WAARSCHUWING : Wanneer meubels omvallen, kaner ernstig of levens bedreigend beklemmingsletsels ontstaan. Om te voorkomen dat dit meubel omvalt, dient dit permanent met de meegeleverde wandbevestigingen aan de wand te worden bevestigd. Bevestigingsbeslag voor de wand is niet inbegrepen, aangezien verschillende soorten bevestigingsbeslag dat geschikt is voor de wanden in je huis.

PT

CUIDADO: Riscos de ferimentos mortais ou graves em caso de tombamento do mobiliário. Para evitar o tombamento do mobiliário, é necessário fixá-lo permanentemente na parede com as peças de fixação incluídas. Os parafusos e cavilhas não estão incluídos, a sua escolha depende do material da parede em que o mobiliário será fixado. Utilizar parafusos e cavilhas adaptados de acordo com o material da parede.

IT

ATTENZIONE: rischio di lesioni gravi o morte se il mobile si rovescia. Per evitare che i mobili si ribaltino, devono essere fissati in modo permanente alla parete utilizzando gli elementi di fissaggio inclusi. Viti e tasselli non sono inclusi perché la loro scelta dipende dal materiale del muro a cui il mobile è attaccato. Usare viti e tasselli adatti al materiale della parete.

DE

ACHTUNG : Wenn Möbelstücke umkippen, können ernste oder lebensgefährliche Verletzungen durch Einklemmen die Folge sein. Um zu verhindern, dass dieses Möbelstück umkippt, muss es mit der beigegepackten Vorrichtung zur Wandbefestigung fest an der Wand verankert werden. Beschläge für die Wandbefestigung sind nicht beigegepackt, da sie von der Beschaffenheit der Wand und des Untergrundmaterials abhängig sind. Befestigungsbeschläge.

GARANTIE / GARANTÍA / WARRANTY / GARANTIA / GARANZIA

FR

Alice's Garden garantit toutes les pièces du produit contre tout vice de fabrication et de matériau pendant une période de 2 ans à compter de la date de réception par le consommateur.

LISTE DES EXCLUSIONS DE GARANTIE

- Le non-respect des conseils d'utilisation du constructeur.

ES

Alice's Garden garantiza que todas las piezas del producto están libres de defectos de fabricación y materiales durante un periodo de 2 años a partir de la fecha de recepción por parte del consumidor.

LISTA DE EXCLUSIONES DE LA GARANTÍA

- No seguir las instrucciones de uso del fabricante.

EN

Alice's Garden warrants all parts of the product to be free from defects in workmanship and materials for a period of 2 years from the date of receipt by the consumer.

LIST OF WARRANTY EXCLUSIONS

- Failure to follow the manufacturer's instructions for use.

NL

Alice's Garden garandeert dat alle onderdelen van het product vrij zijn van fabricage- en materiaalfouten gedurende een periode van 2 jaar vanaf de datum van ontvangst door de consument.

LIJST VAN GARANTIE-UITSLUITINGEN

- Het niet volgen van de gebruiksaanwijzing van de fabrikant.

PT

Alice's Garden garante que todas as partes do produto estão livres de defeitos de fabrico e materiais durante um período de 2 anos a partir da data da sua recepção pelo consumidor.

LISTA DE EXCLUSÕES DE GARANTIA

- Não seguir as instruções de utilização do fabricante.

IT

Alice's Garden garantisce che tutte le parti del prodotto sono prive di difetti di lavorazione e di materiali per un periodo di 2 anni dalla data di ricevimento da parte del consumatore.

ELENCO DELLE ESCLUSIONI DALLA GARANZIA

- Mancata osservanza delle istruzioni d'uso del produttore.

DE

Alice's Garden garantiert für einen Zeitraum von zwei Jahren ab dem Datum des Erhalts durch den Verbraucher, dass alle Teile des Produkts frei von Verarbeitungs- und Materialfehlern sind.

LISTE DER GARANTIEAUSSCHLÜSSE

- Die Nichtbeachtung der Gebrauchshinweise des Herstellers.

MONTAGE / MONTAJE / ASSEMBLY / ASSEMBLEIA / MONTAGGIO

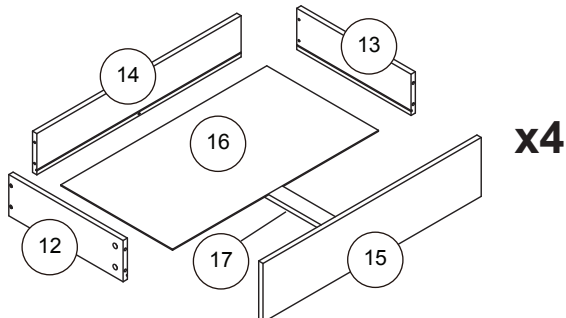
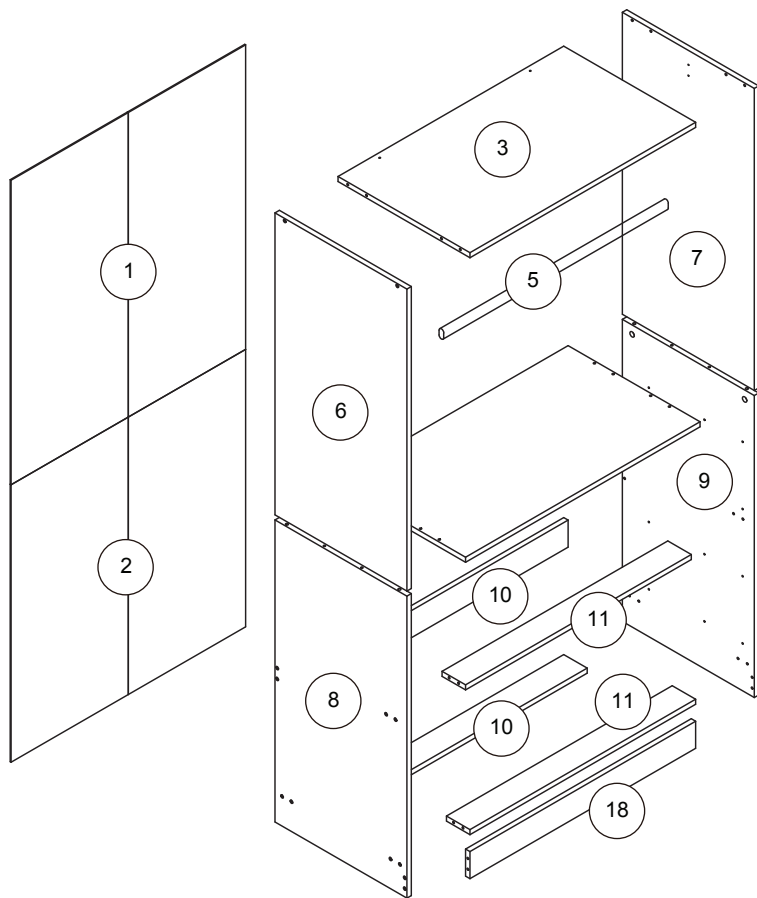

A



6x35mm
x 24

B



15x10mm
x 24

C



4x35mm
x 48

D



3x14mm
x 34

E



6x30mm
x 4

F



6x50mm
x 4

G



3,5x14mm
x 4

H



x 24

I



x 2

J



3x12mm
x 48

K



x 2

CL



x 4

CR



x 4

DL



x 4

DR



x 4

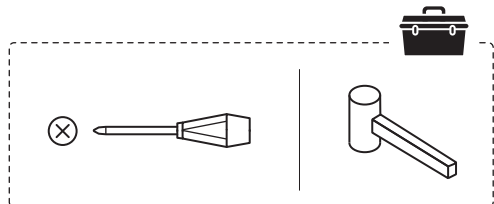

1

A x4

D x2

I x2

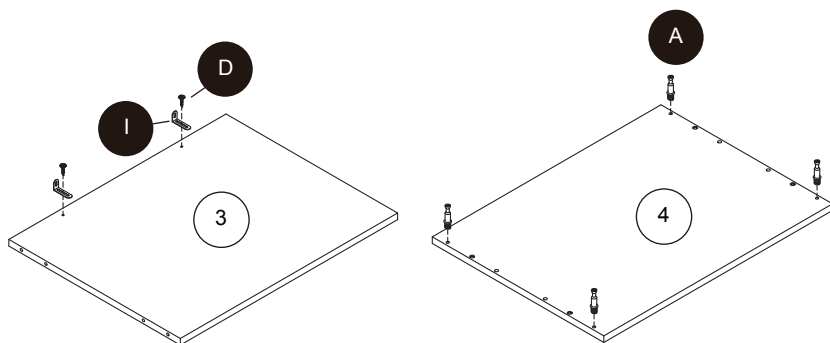

2

K x2

G x4

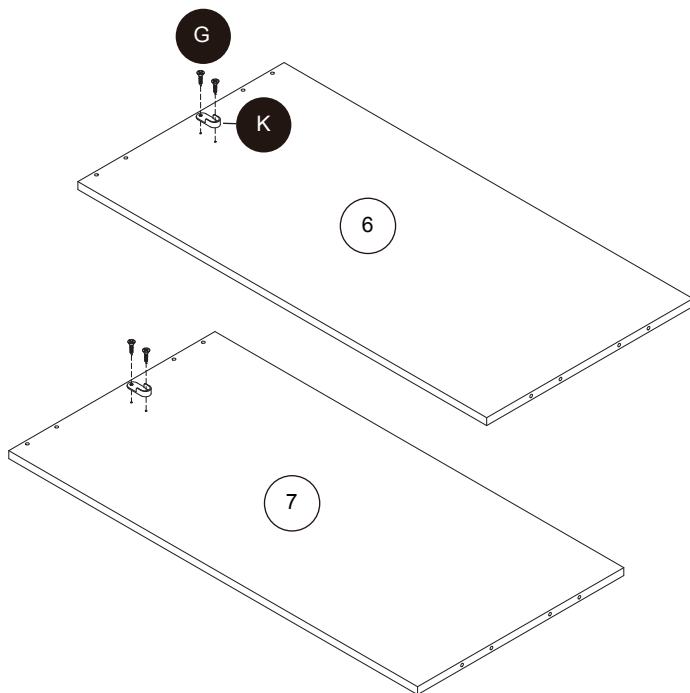

3

C x4
E x4
H x4

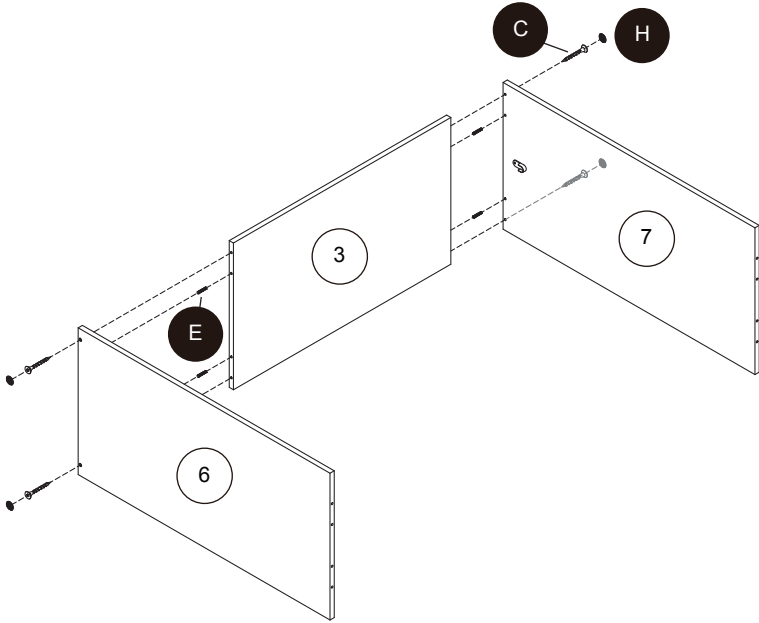

4

C x4
F x4

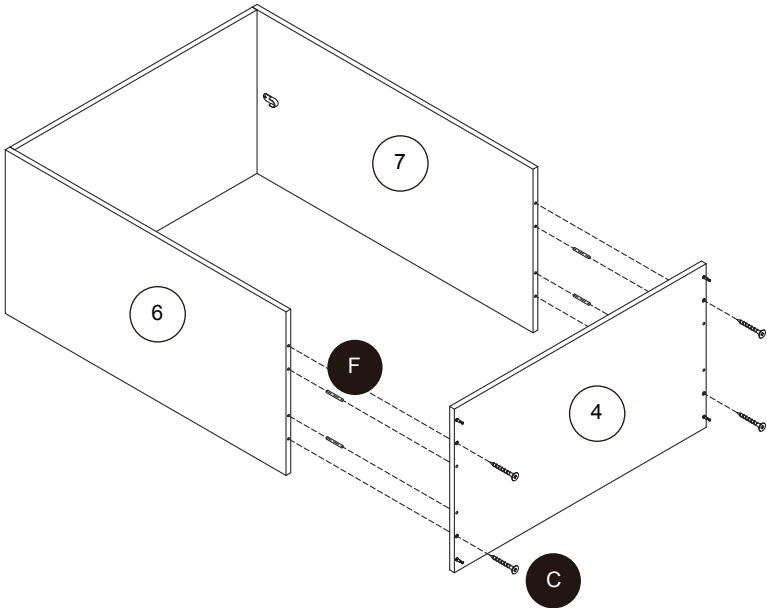

5

J x12
CL x4

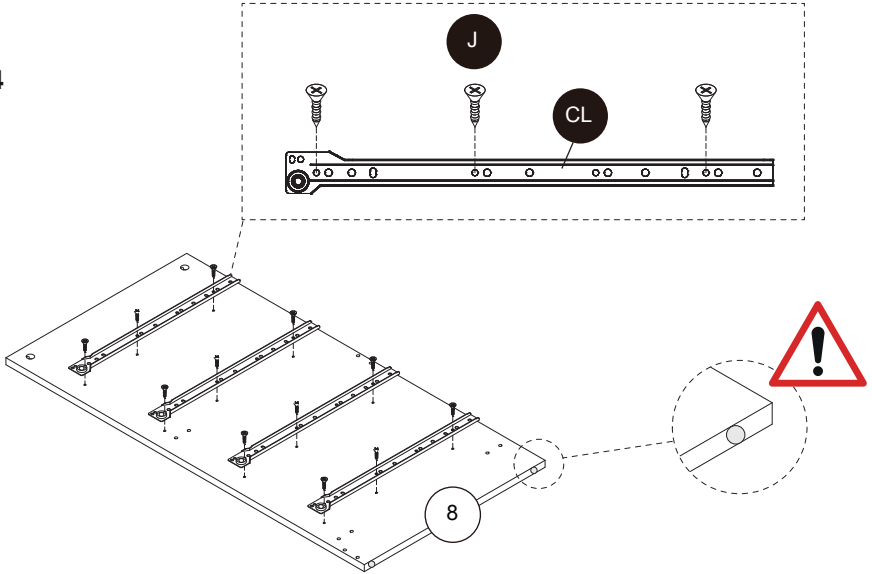

6

J x12
CR x4

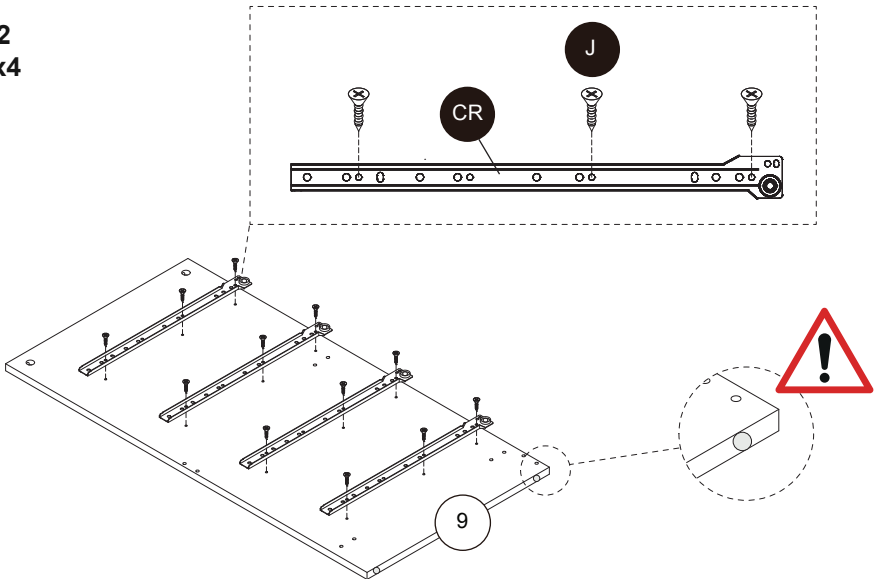

7

C x10
H x10

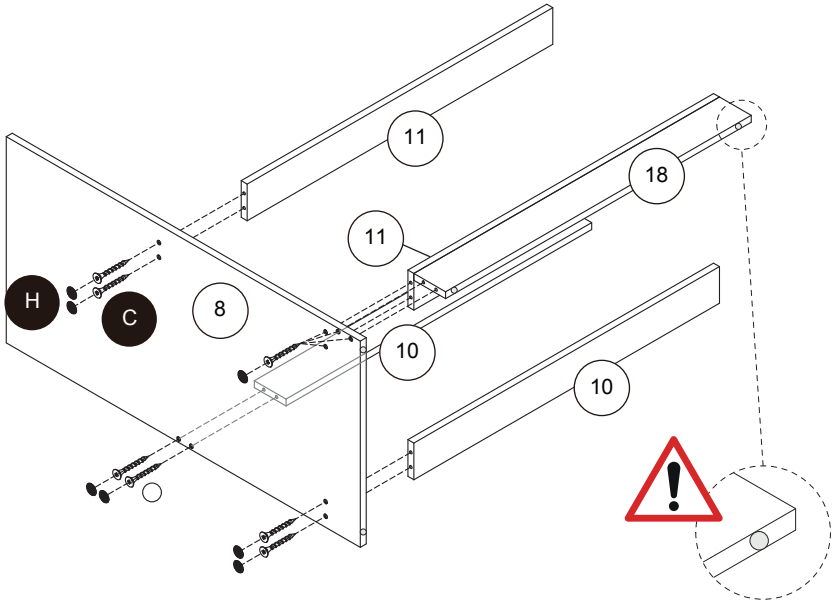

8

C x10
H x10

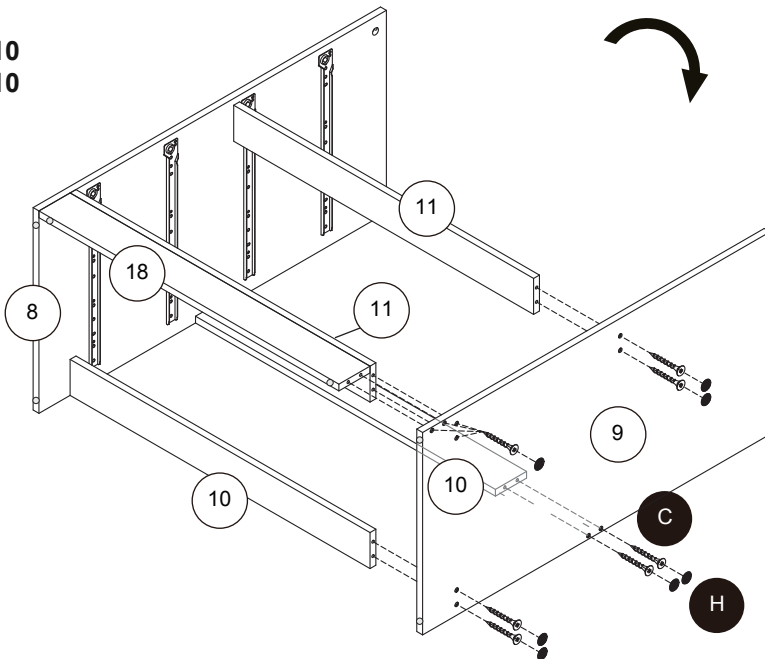

9

B x4

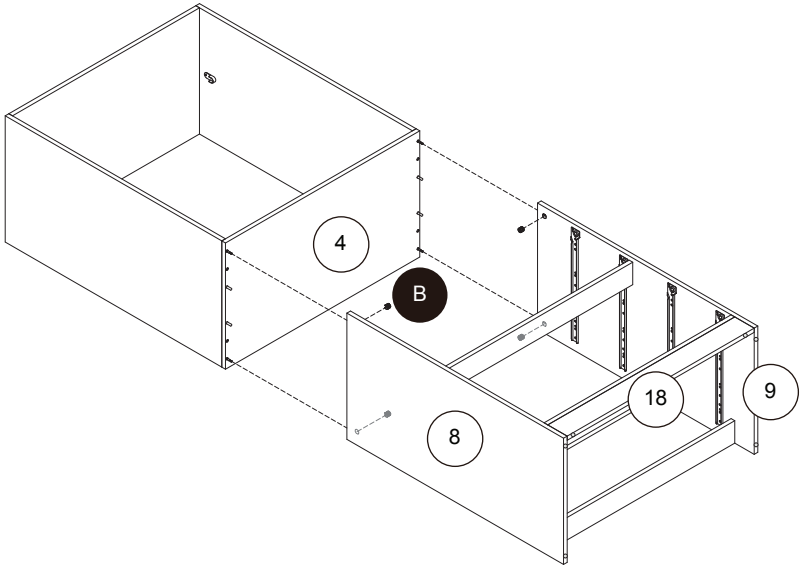

10

D x4
G x32

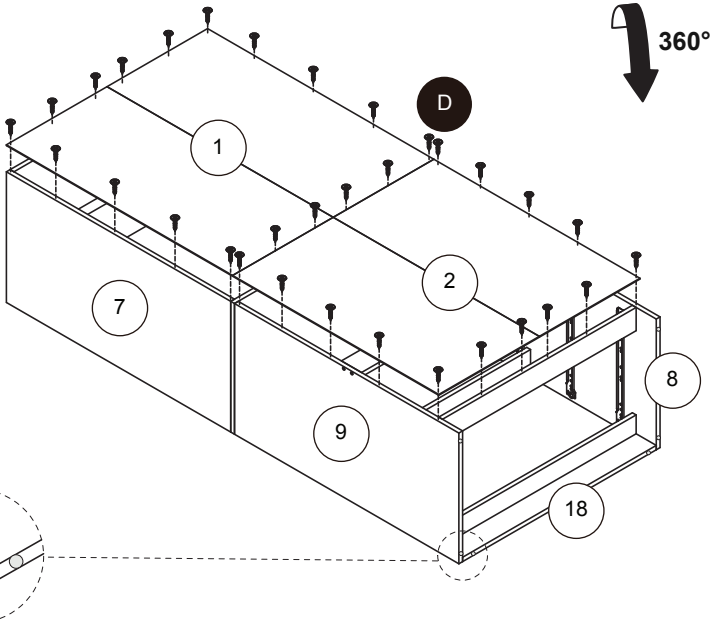

11

C x20

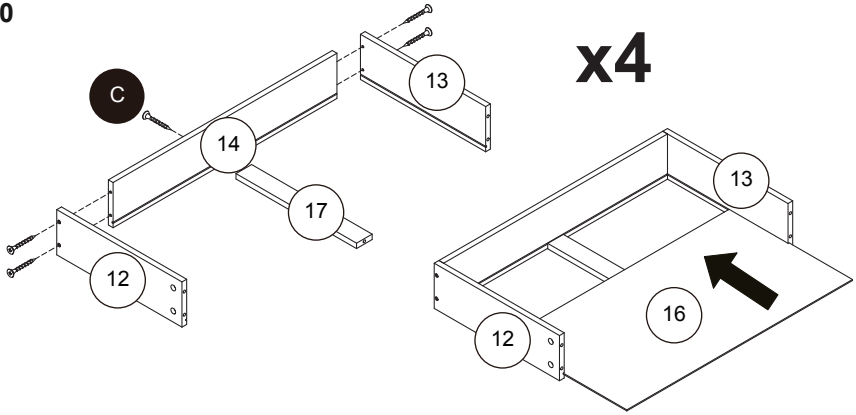

12

A x20

B x20

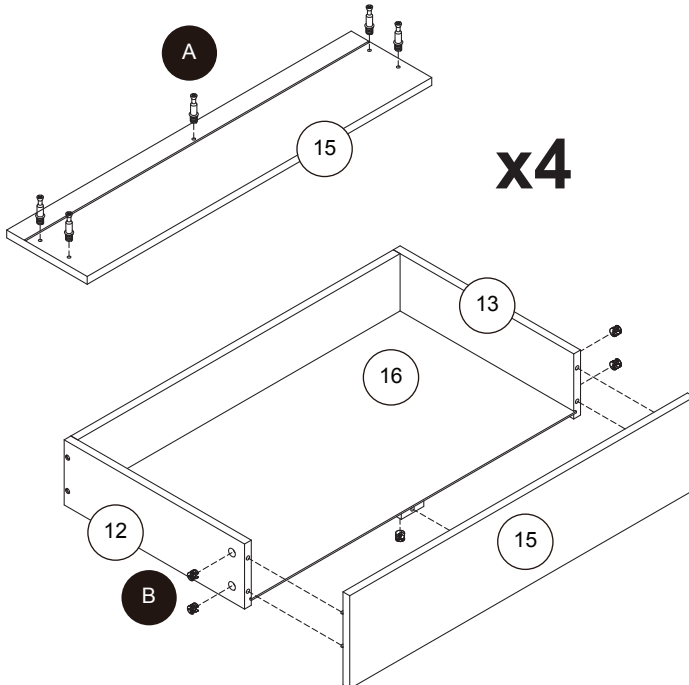

13

J x24
DL x4
DR x4

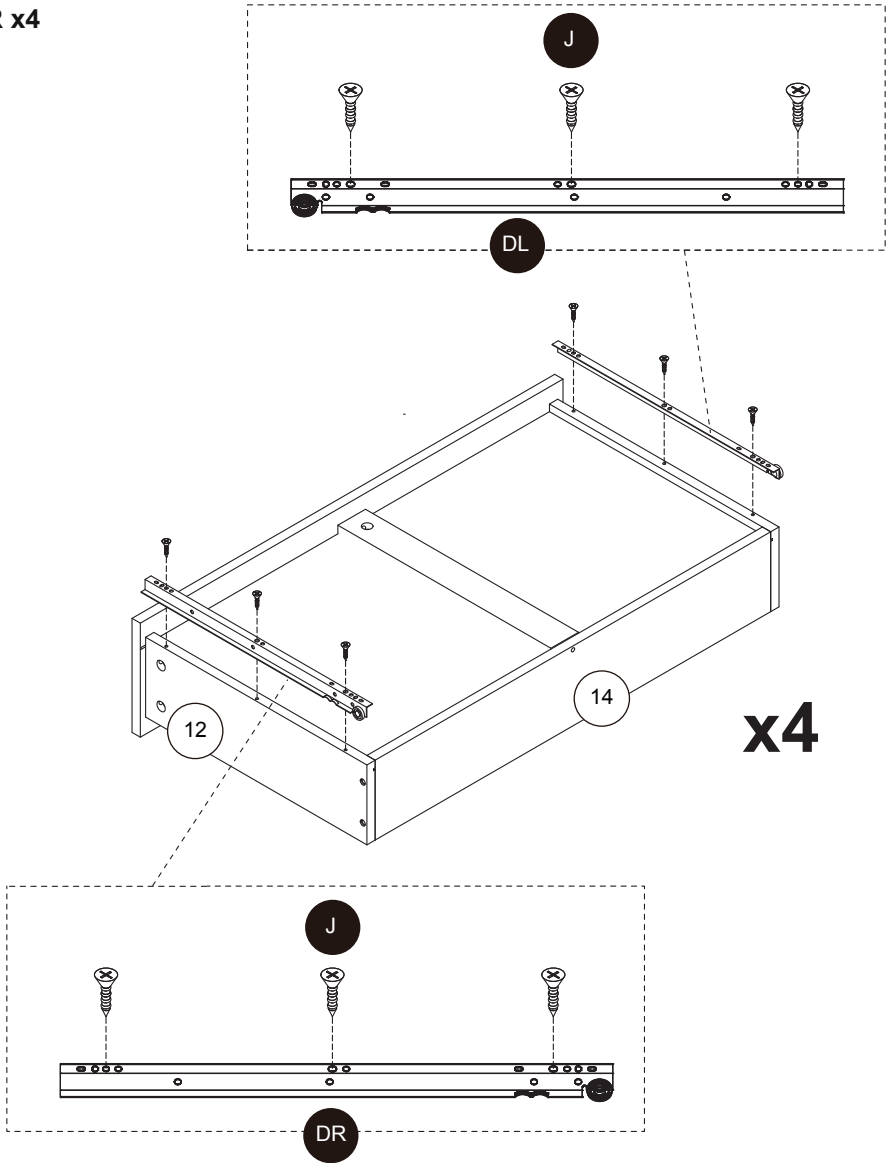

14

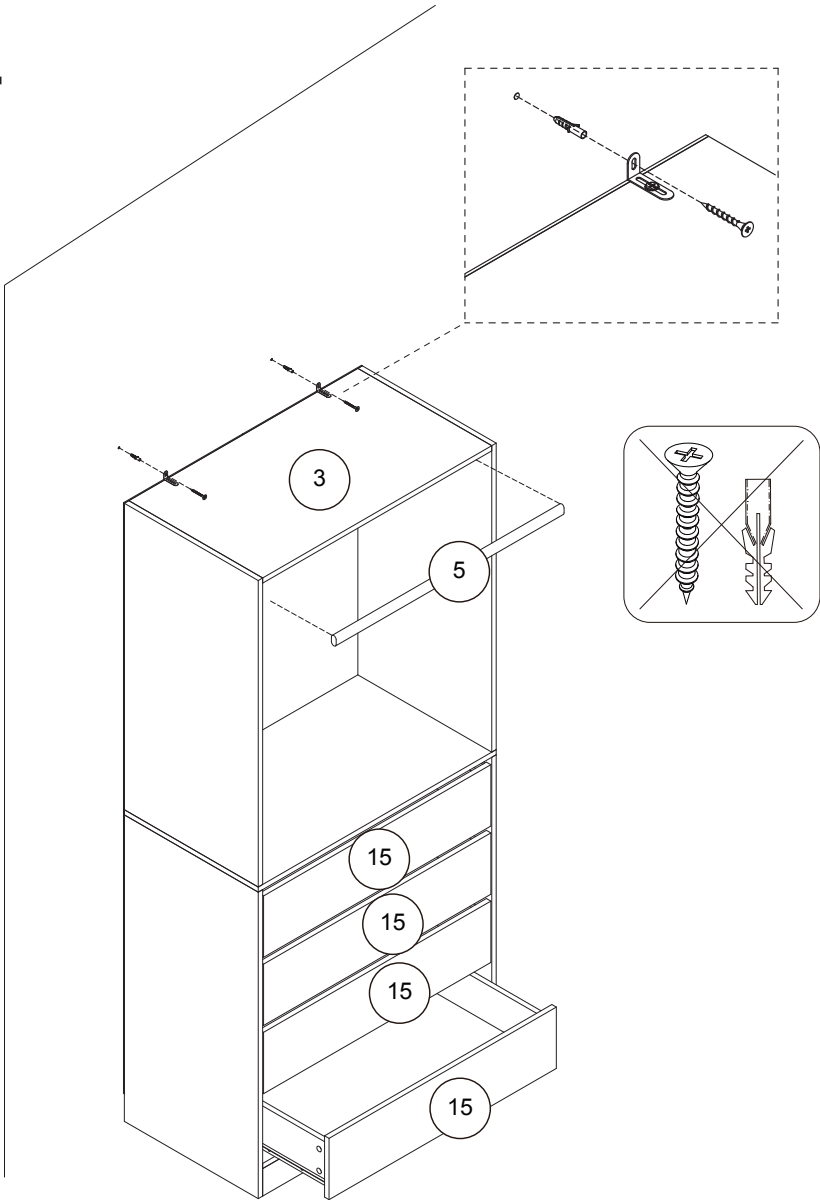

15

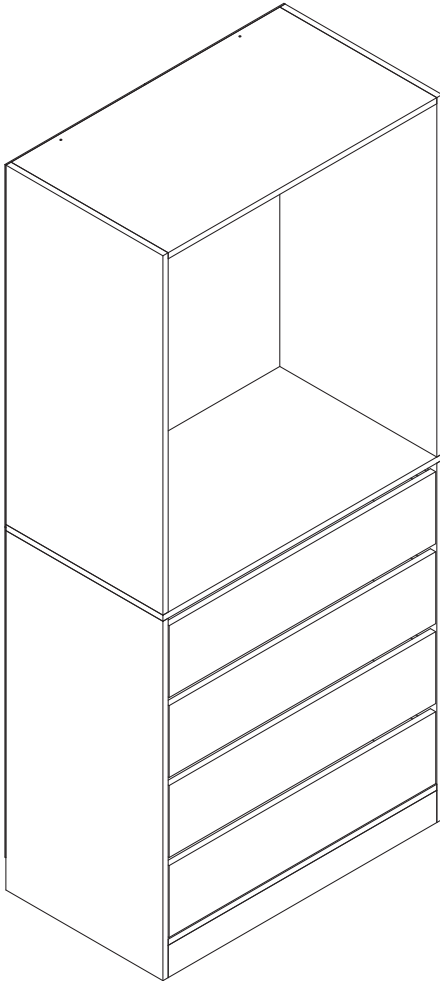

IMPORTÉ PAR WALIBUY SAS
270 avenue de l'Espace, 59118 WAMBRECHIES - FRANCE
Service après vente : sav.alicesgarden.fr - sav.alicesgarden.be

IMPORTADO POR WALIBUY SPAIN SL
Carrer de Mallorca 289, Entresuelo 2, 08037 BARCELONA - ESPAÑA
Servicio postventa : alicesgarden.es/cms/contacto

IMPORTED BY ALICE'S GARDEN UK LTD
23 Copenhagen Street, LONDON N10JB - UNITED KINGDOM
After sales service: alicesgarden.co.uk/cms/contact-us

INGEVOERD DOOR WALIBUY SAS
270 avenue de l'Espace, 59118 WAMBRECHIES - FRANKRIJK
After-sales : aftersales.alicesgarden.nl - aftersales.alicesgarden.be

IMPORTADO PARA WALIBUY SPAIN SL
Carrer de Mallorca 289, Entresuelo 2, 08037 BARCELONA - ESPAÑA
Serviço pós-venda : alicesgarden.pt/cms/contato

IMPORTATO DA WALIBUY ITALIA S.R.L
Via Torino 60, 20123 MILANO - ITALIA
Contatto : contatto@alicesgarden.it

IMPORTED BY ALICE'S GARDEN OUTDOOR PTY LTD
135-153 New South Head Road, Edgecliff NSW 2027 - AUSTRALIA
Contact : service@alicesgarden.com.au

IMPORTIERT VON WALIBUY SAS
270 AVENUE DE L'ESPACE, 59118 WAMBRECHIES - FRANKREICH
Kundendienst : kundenservice@alicesgarden.de



FR

Donnez ou recyclez
vos meubles.



Association

ou



Magasin

ou



Déchèterie

<https://quefairedemesdechets.fr>

IDRES5D

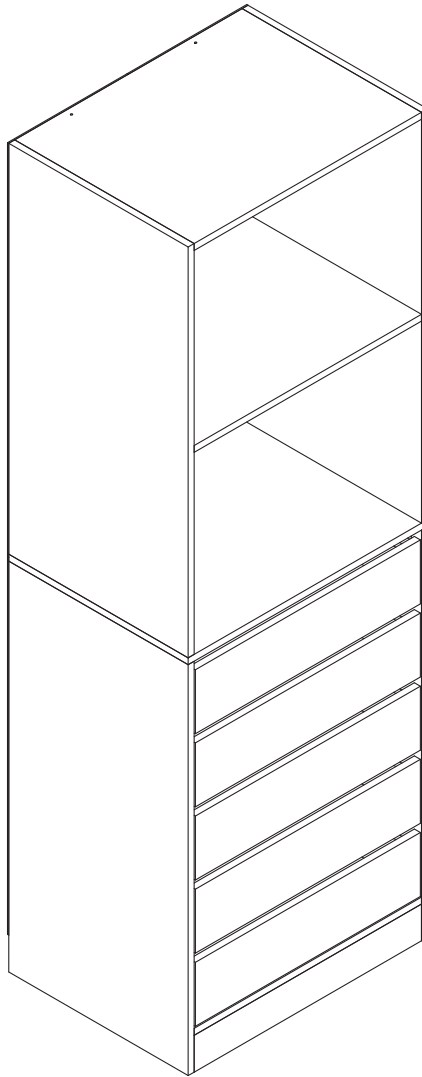

FRANÇAIS

Conseils d'entretien.....	6
Conseils d'utilisation.....	7
Avertissements.....	8
Garantie.....	9
Montage.....	10

**IMPORTANT, À CONSERVER
POUR CONSULTATION ULTÉRIEURE :
À LIRE ATTENTIVEMENT**

ESPAÑOL

Instrucciones de mantenimiento.....	6
Instrucciones de uso.....	7
Advertencia.....	8
Garantía.....	9
Montaje.....	10

**IMPORTANTE, CONSÉRVELO
PARA FUTURAS REFERENCIAS:
LEA ATENTAMENTE**

ENGLISH

Directions for use.....	6
Directions for use.....	7
Warning.....	8
Warranty.....	9
Assembly.....	10

**IMPORTANT, RETAIN FOR FUTURE
REFERENCE: PLEASE READ
CAREFULLY**

NEDERLANDS

Onderhoud.....	6
Gebruiksaanwijzingen	7
Waarschuwingen	8
Garantie.....	9
Montage.....	10

**BELANGRIJK, BEWAAR VOOR
TOEKOMSTIGE REFERENTIE:
ZORGVULDIG LEZEN**

PORTUGUÊS

Instruções para manutenção	6
Instruções de utilização	7
Advertência.....	8
Garantia.....	9
Assembleia.....	10

**IMPORTANTE, CONSERVE A
REFERÊNCIA DA FATURA:
LEIA CUIDADOSAMENTE**

ITALIANO

Consigli per la manutenzione	6
Consigli per l'uso	7
Avvertenze.....	8
Garanzia.....	9
Montaggio.....	10

**IMPORTANTE, CONSERVARE PER
ULTERIORI CONSULTAZIONI:
LEGGERE ATTENTAMENTE**

DEUTSCH

Pflegehinweis	6
Anwendungen	7
Warnhinweise	8
Garantie	9
Montage	10

**WICHTIG, FÜR SPÄTEREN
GEBRAUCH AUFBEWAHREN:
AUFMERKSAM LESEN**



Garantie : 2 ans
Garantía : 2 años
Warranty: 2 years
Garantie: 2 jaar
Garantia: 2 anos
Garanzia : 2 anni
Garantie: 2 Jahre



Destiné à un usage domestique
Destinado a un uso doméstico
For domestic use only
Bestemd voor huishoudelijk gebruik
Para uso doméstico
Destinato ad un uso domestico
Für den Haushaltsgebrauch vorgesehen



Attention : risques de blessures
Cuidado : riesgo de lesión
Warning : risk of injuries
Waarschuwing: risico op verwondigen
Cuidado: risco de ferimentos
Attenzione : rischio infortunio
Warnung: Verletzungsgefahr



Poids maximal : 50 kg
Peso máximo : 50 kg
Maximum weight: 50 kg
Maximale gewicht: 50 kg
Peso máximo: 50 kg
Peso massimo: 50 kg
Maximales gewicht: 50 kg

CONSEILS D'ENTRETIEN / INSTRUCCIONES DE MANTENIMIENTO / DIRECTIONS FOR USE / ONDERHOUD / INSTRUÇÕES DE UTILIZAÇÃO / CONSIGLI PER LA MANUTENZIONE / PFLEGEHINWELS

FR

Dépoussiérer régulièrement avec un chiffon propre, doux et sec.
Proscrire tout abrasif et produits acides. Ne jamais employer de solvants.

ES

Quitar el polvo regularmente con un paño limpio, suave y seco.
No utilice productos abrasivos o ácidos. No utilice nunca disolventes de limpieza.

EN

Regularly dust with a clean, soft and dry cloth.
Do not use any abrasive or acidic products. Never use cleaning solvents.

NL

Stof regelmatig af met een schone, zachte en droge doek.
Sluit alle schurende en zure producten uit. Gebruik nooit oplosmiddelen

PT

Pó regularmente com um espanador limpo, macio e seco.
Proibir qualquer esfregão e produtos ácidos. Nunca utilizar solvente de limpeza.

IT

Spolverare regolarmente con un panno pulito, morbido e asciutto.
Non usare prodotti abrasivi o acidi. Non usare mai solventi.

DE

Regelmäßig mit einem sauberen, weichen und trockenen Tuch abstauben.
Keinesfalls abrasive und ätzende Reinigungsprodukte anwenden. Verwenden Sie niemals Lösungsmittel.

CONSEILS D'UTILISATION / INSTRUCCIONES DE USO / DIRECTIONS FOR USE / GEBRUIKSIINSTRUCTIES / INSTRUÇÕES DE UTILIZAÇÃO / CONSIGLI PER L'USO / ANWENDUNGS

FR

Pour des raisons de stabilité, et afin de préserver les pas et les vis d'un serrage de travers, impératif d'assembler manuellement tous les éléments, et de serrer toutes les vis à la main dans un premier temps. Une fois l'assemblage terminé, vous pouvez procéder au serrage de la visserie de manière plus ferme.

Attention, ne pas s'asseoir sur le produit. En effet, cela peut entraîner une dégradation du produit, voire des blessures, n'entrant pas dans le cadre de la garantie.

ES

Para garantizar la estabilidad y evitar que las roscas de los tornillos se deformen, es imprescindible empezar por montar y atornillar cada pieza a mano. Una vez completado el montaje, se puede proceder a apretar los tornillos con mayor firmeza.

No se siente sobre el producto. De lo contrario, el producto podría resultar dañado o incluso sufrir lesiones, lo que no está cubierto por la garantía.

EN

To ensure stability and in order to prevent the screw threads from becoming deformed, it is essential to start by assembling and screwing in each piece by hand. Once the assembly is complete, you can proceed to tighten the screws more firmly.

Do not sit on the product. Doing so may result in damage to the product or even injury, which is not covered by the warranty.

NL

Omwille van de stabiliteit en om doordraaien te voorkomen, is het van cruciaal belang om alle elementen handmatig te monteren en alle schroeven in eerste instantie met de hand aan te halen. Na de montage kunt u de schroeven steviger vastzetten.

Ga niet op het product zitten. Dit kan leiden tot schade aan het product of zelfs letsel, wat niet onder de garantie valt.

PT

Por razões de estabilidade e a fim de preservar o alinhamento da estrutura, é imperativo montar cada peça à mão em primeiro lugar. Uma vez terminada a montagem, é possível proceder ao aperto firme do parafuso.

Não se sentar sobre o produto. Fazê-lo pode resultar em danos no produto ou mesmo em ferimentos, que não estão cobertos pela garantia.

IT

Per ragioni di stabilità e per proteggere le filettature delle viti da un errato serraggio, è imperativo assemblare tutti gli elementi a mano e stringere tutte le viti a mano all'inizio. Una volta completato il montaggio, le viti possono essere serrate più saldamente.

Non sedersi sul prodotto. Ciò potrebbe causare danni al prodotto o addirittura lesioni, che non sono coperte dalla garanzia.

DE

Aus Stabilitätsgründen und um ein Überziehen der Gewinde zu verhindern, müssen unbedingt alle Komponenten manuell zusammengebaut und alle Schrauben zuerst von Hand angezogen werden. Sobald die Montage abgeschlossen ist, können Sie die Hardware fester anziehen.

Setzen Sie sich nicht auf das Produkt. Dies kann nämlich zu einer Beschädigung des Produkts oder sogar zu Verletzungen führen, die nicht unter die Garantie fallen.

AVERTISSEMENTS / WAARSCHUWINGEN / WARNHINWEISE / WARNING / ADVERTENCIA / ADVERTÊNCIA / AVVERTENZE

FR

ATTENTION : Risque de blessure grave ou mortelle en cas de basculement du meuble. Pour éviter que le meuble ne bascule, il faut le fixer au mur de façon permanente à l'aide des pièces incluses pour la fixation. Les vis et chevilles ne sont pas incluses car leur choix dépend du matériau du mur sur lequel est fixé le meuble. Utilisez des vis et chevilles adaptées au matériau du mur.

ES

PRECAUCIÓN: Riesgo de lesiones mortales o graves en caso de que el mueble se vuelque. Para evitar que el mueble se caiga, debe fijarlo a la pared de forma permanente con las piezas de fijación incluidas. Los tornillos y tacos no están incluidos, ya que la selección de estas piezas depende del material de la pared en la que se fijará el mueble. Utilice los tornillos y tacos adecuados para el material de su pared.

EN

Caution: Risk of mortal or serious injuries in case of the furniture toppling over. To avoid the furniture falling, you must fix it to the wall permanently with the included fixing pieces. Screws and dowels are not included, as the selection of these parts is dependent on the wall material that the furniture will be fixed to. Use the correct screws and dowels for your wall material.

NL

WAARSCHUWING : Wanneer meubels omvallen, kaner ernstig of levens bedreigend beklemmingsletsels ontstaan. Om te voorkomen dat dit meubel omvalt, dient dit permanent met de meegeleverde wandbevestigingen aan de wand te worden bevestigd. Bevestigingsbeslag voor de wand is niet inbegrepen, aangezien verschillende soorten bevestigingsbeslag dat geschikt is voor de wanden in je huis.

PT

CUIDADO: Riscos de ferimentos mortais ou graves em caso de tombamento do mobiliário. Para evitar o tombamento do mobiliário, é necessário fixá-lo permanentemente na parede com as peças de fixação incluídas. Os parafusos e cavilhas não estão incluídos, a sua escolha depende do material da parede em que o mobiliário será fixado. Utilizar parafusos e cavilhas adaptados de acordo com o material da parede.

IT

ATTENZIONE: rischio di lesioni gravi o morte se il mobile si rovescia. Per evitare che i mobili si ribaltino, devono essere fissati in modo permanente alla parete utilizzando gli elementi di fissaggio inclusi. Viti e tasselli non sono inclusi perché la loro scelta dipende dal materiale del muro a cui il mobile è attaccato. Usare viti e tasselli adatti al materiale della parete.

DE

ACHTUNG : Wenn Möbelstücke umkippen, können ernste oder lebensgefährliche Verletzungen durch Einklemmen die Folge sein. Um zu verhindern, dass dieses Möbelstück umkippt, muss es mit der beigegepackten Vorrichtung zur Wandbefestigung fest an der Wand verankert werden. Beschläge für die Wandbefestigung sind nicht beigegepackt, da sie von der Beschaffenheit der Wand und des Untergrundmaterials abhängig sind. Befestigungsbeschläge.

GARANTIE / GARANTÍA / WARRANTY / GARANTIA / GARANZIA

FR

Alice's Garden garantit toutes les pièces du produit contre tout vice de fabrication et de matériau pendant une période de 2 ans à compter de la date de réception par le consommateur.

LISTE DES EXCLUSIONS DE GARANTIE

- Le non-respect des conseils d'utilisation du constructeur.

ES

Alice's Garden garantiza que todas las piezas del producto están libres de defectos de fabricación y materiales durante un periodo de 2 años a partir de la fecha de recepción por parte del consumidor.

LISTA DE EXCLUSIONES DE LA GARANTÍA

- No seguir las instrucciones de uso del fabricante.

EN

Alice's Garden warrants all parts of the product to be free from defects in workmanship and materials for a period of 2 years from the date of receipt by the consumer.

LIST OF WARRANTY EXCLUSIONS

- Failure to follow the manufacturer's instructions for use.

NL

Alice's Garden garandeert dat alle onderdelen van het product vrij zijn van fabricage- en materiaalfouten gedurende een periode van 2 jaar vanaf de datum van ontvangst door de consument.

LIJST VAN GARANTIE-UITSLUITINGEN

- Het niet volgen van de gebruiksaanwijzing van de fabrikant.

PT

Alice's Garden garante que todas as partes do produto estão livres de defeitos de fabrico e materiais durante um período de 2 anos a partir da data da sua recepção pelo consumidor.

LISTA DE EXCLUSÕES DE GARANTIA

- Não seguir as instruções de utilização do fabricante.

IT

Alice's Garden garantisce che tutte le parti del prodotto sono prive di difetti di lavorazione e di materiali per un periodo di 2 anni dalla data di ricevimento da parte del consumatore.

ELENCO DELLE ESCLUSIONI DALLA GARANZIA

- Mancata osservanza delle istruzioni d'uso del produttore.

DE

Alice's Garden garantiert für einen Zeitraum von zwei Jahren ab dem Datum des Erhalts durch den Verbraucher, dass alle Teile des Produkts frei von Verarbeitungs- und Materialfehlern sind.

LISTE DER GARANTIEAUSSCHLÜSSE

- Die Nichtbeachtung der Gebrauchshinweise des Herstellers.

MONTAGE / MONTAJE / ASSEMBLY / ASSEMBLEIA / MONTAGGIO

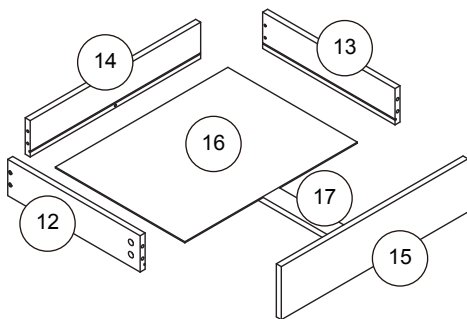
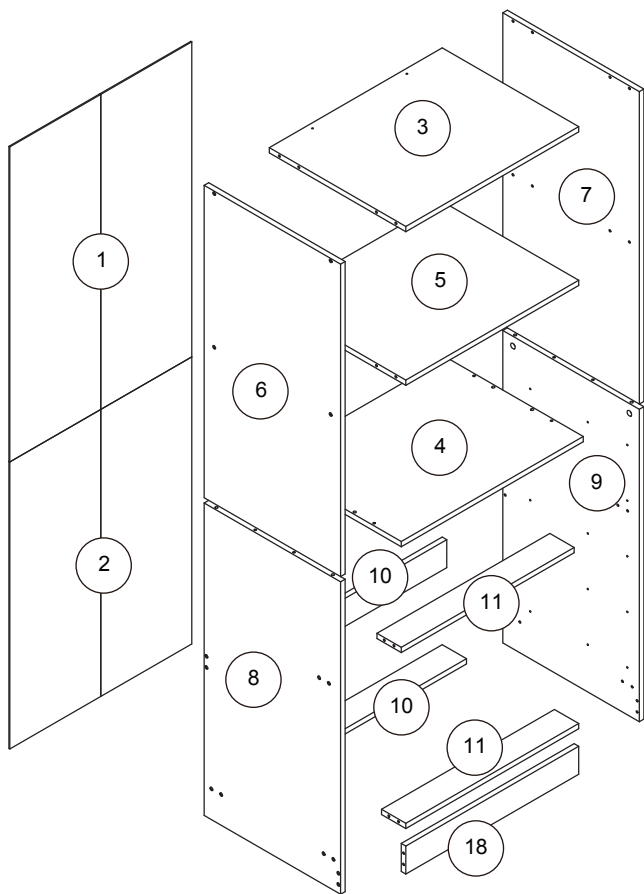

x5

A



6x35mm
× 29

B



15x10mm
× 29

C



4x35mm
× 57

D



3x14mm
× 34

E



6x30mm
× 8

F



6x50mm
× 4

G



3x12mm
× 60

H



× 28

I



× 2

CL



× 5

CR



× 5

DL



× 5

DR



× 5

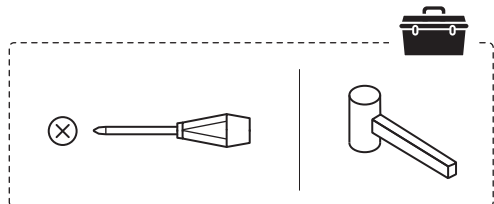

1

A x4
D x2
I x2

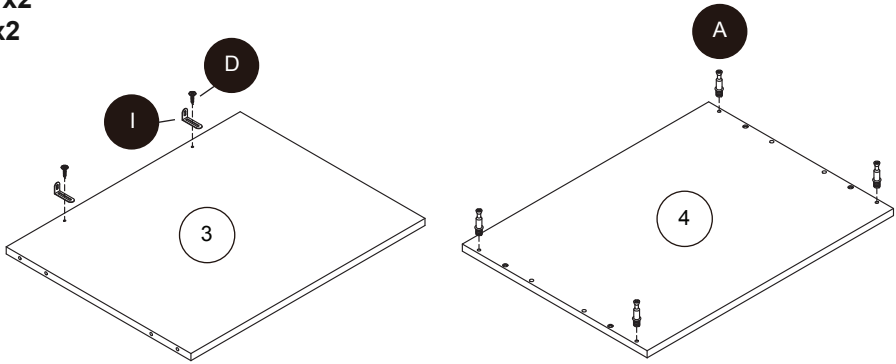

2

C x8
E x8
H x8

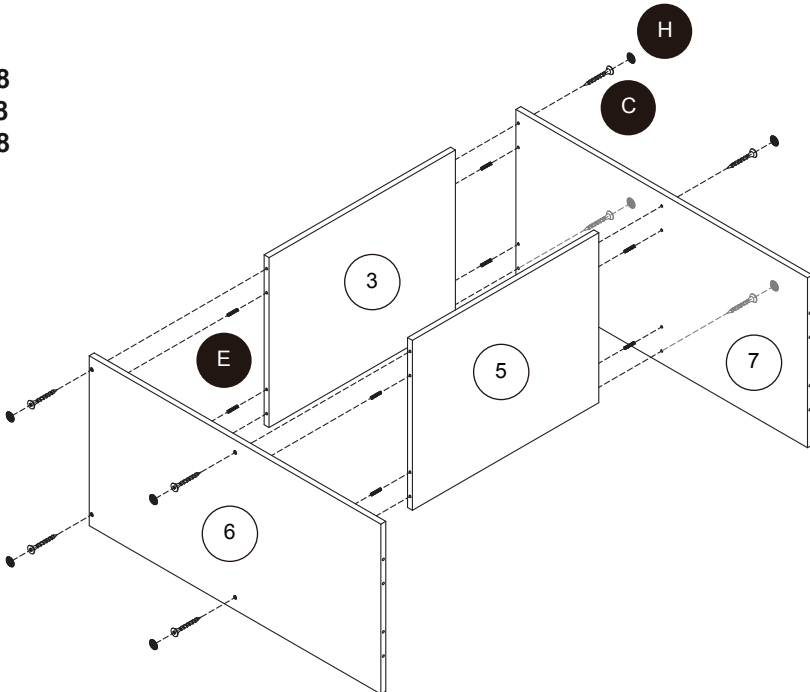

3

C x4
F x4

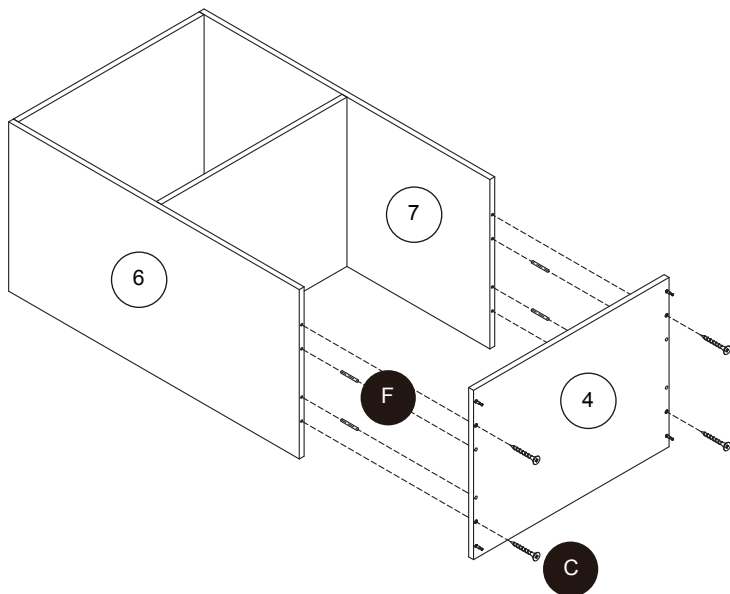

4

G x15
CL x5

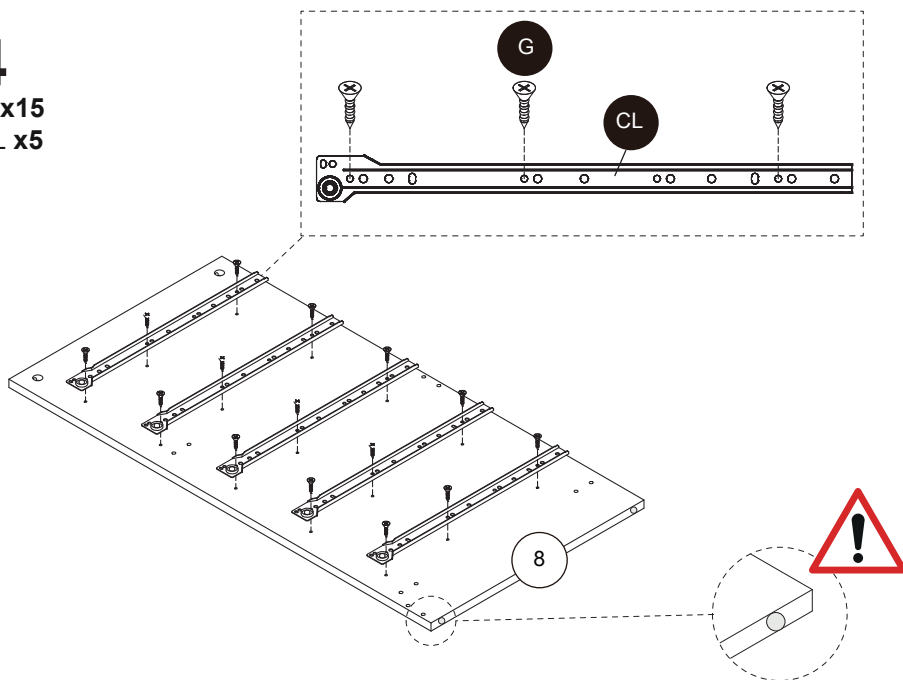

5

G x15
CR x5

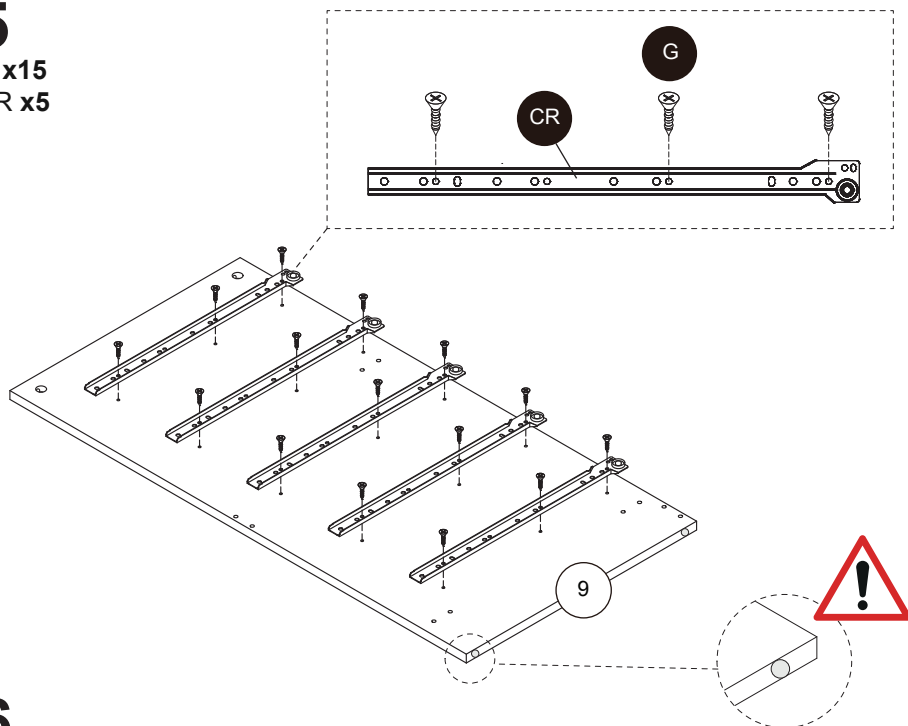

6

C x10
H x10

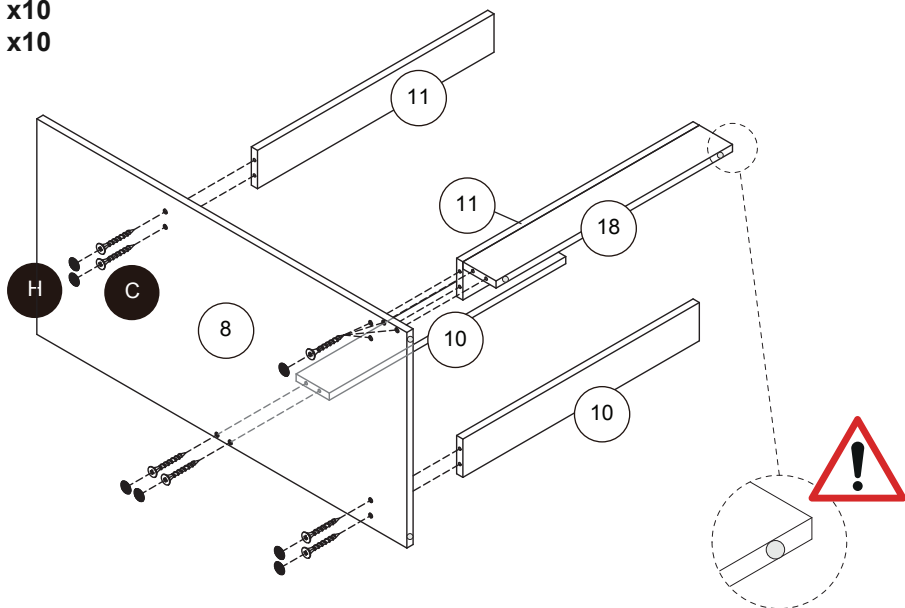

7

C x 10
H x 10

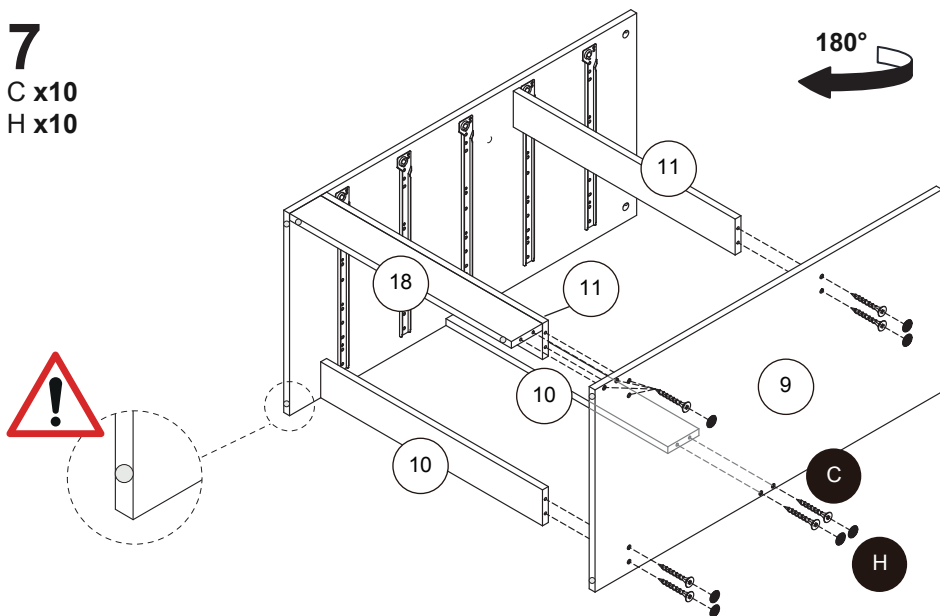

8

B x 4

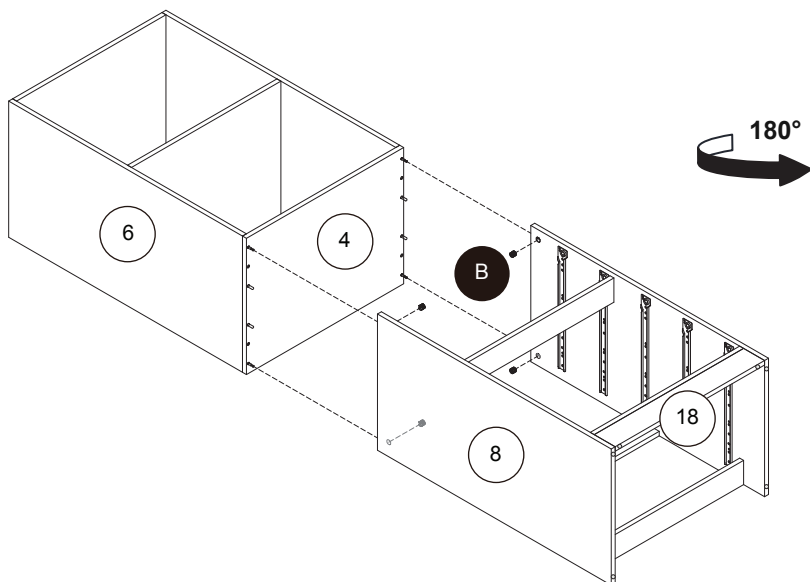

9

D x32

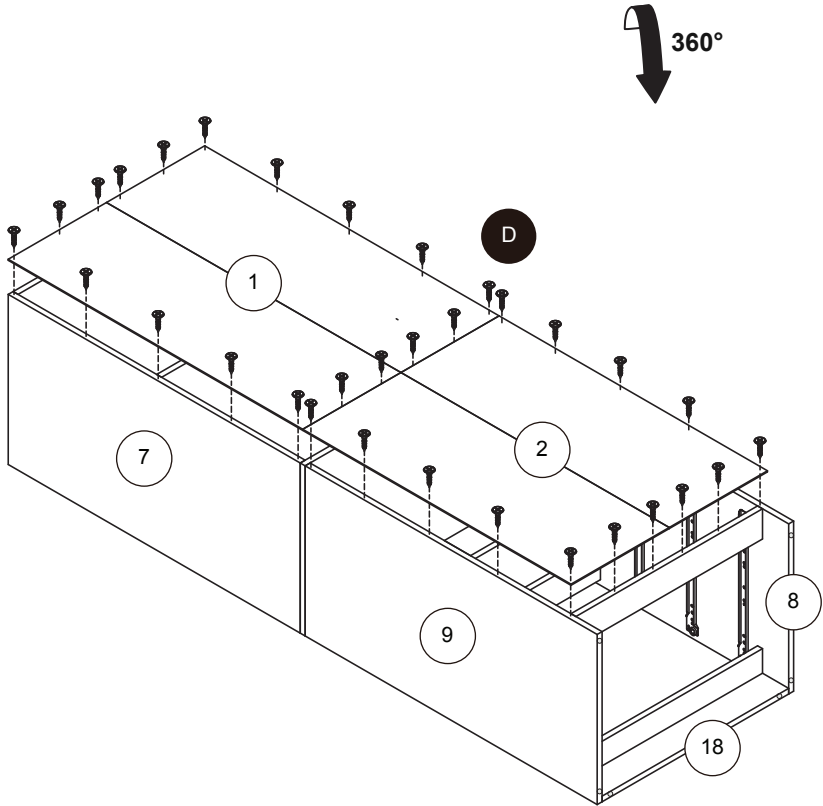

10

C x25

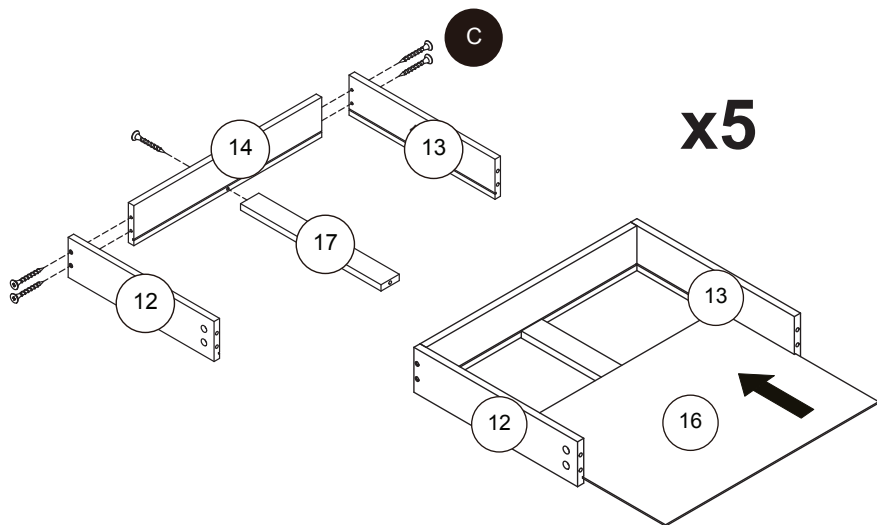

11

A x25
B x25

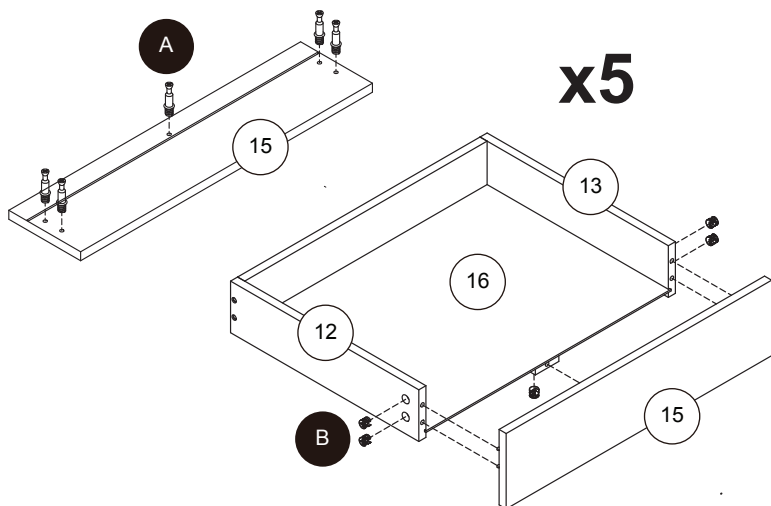

13

G x30

DL x5

DR x5

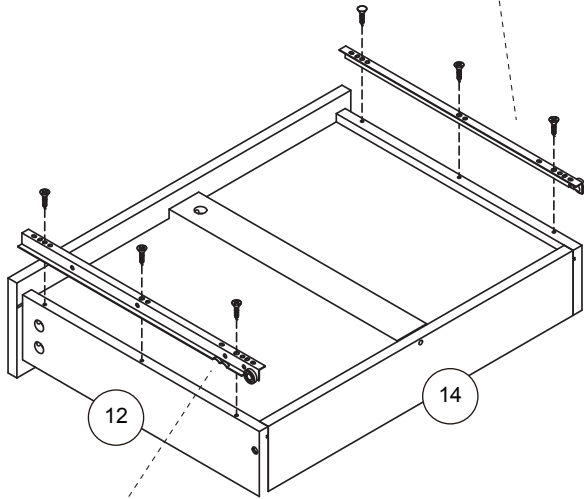
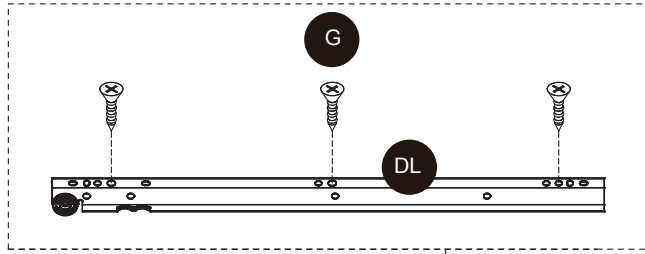

x5

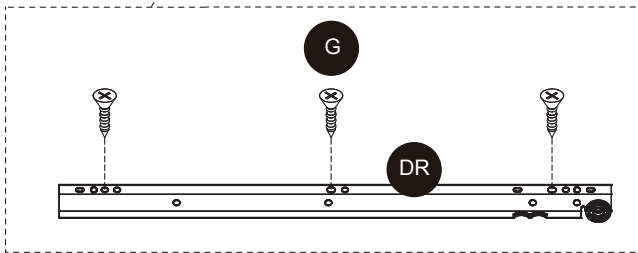

14

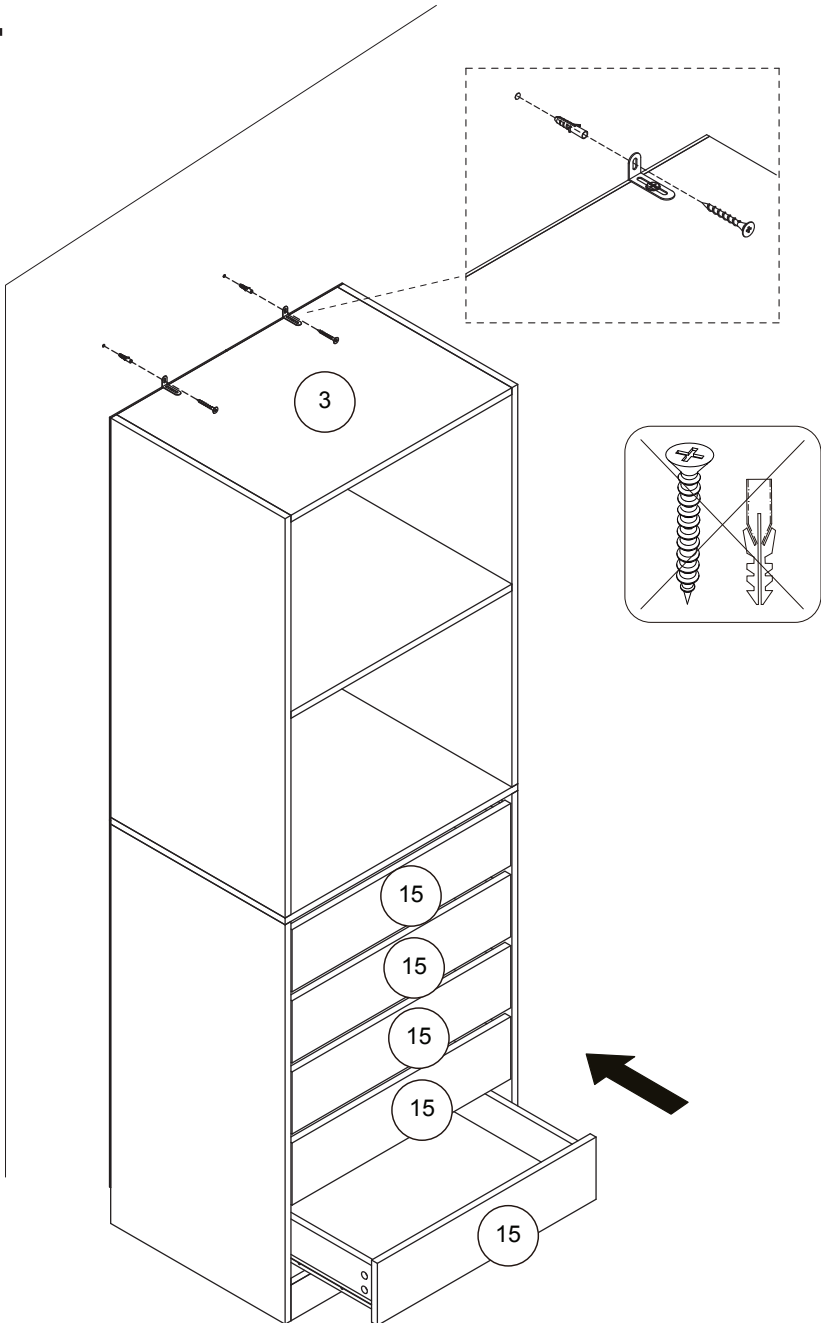

15

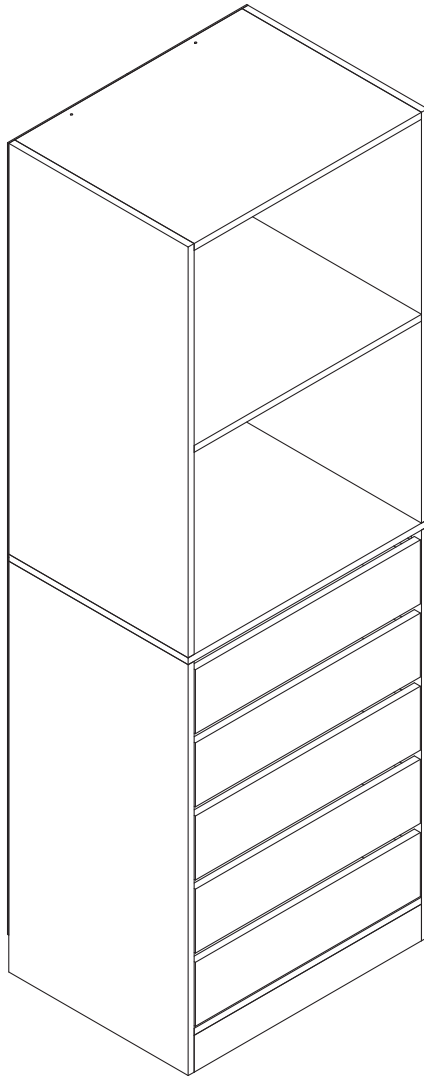

IMPORTÉ PAR WALIBUY SAS
270 avenue de l'Espace, 59118 WAMBRECHIES - FRANCE
Service après vente : sav.alicesgarden.fr - sav.alicesgarden.be

IMPORTADO POR WALIBUY SPAIN SL
Carrer de Mallorca 289, Entresuelo 2, 08037 BARCELONA - ESPAÑA
Servicio postventa : alicesgarden.es/cms/contacto

IMPORTED BY ALICE'S GARDEN UK LTD
23 Copenhagen Street, LONDON N10JB - UNITED KINGDOM
After sales service: alicesgarden.co.uk/cms/contact-us

INGEVOERD DOOR WALIBUY SAS
270 avenue de l'Espace, 59118 WAMBRECHIES - FRANKRIJK
After-sales : aftersales.alicesgarden.nl - aftersales.alicesgarden.be

IMPORTADO PARA WALIBUY SPAIN SL
Carrer de Mallorca 289, Entresuelo 2, 08037 BARCELONA - ESPAÑA
Serviço pós-venda : alicesgarden.pt/cms/contato

IMPORTATO DA WALIBUY ITALIA S.R.L
Via Torino 60, 20123 MILANO - ITALIA
Contatto : contatto@alicesgarden.it

IMPORTED BY ALICE'S GARDEN OUTDOOR PTY LTD
135-153 New South Head Road, Edgecliff NSW 2027 - AUSTRALIA
Contact : service@alicesgarden.com.au

IMPORTIERT VON WALIBUY SAS
270 AVENUE DE L'ESPACE, 59118 WAMBRECHIES - FRANKREICH
Kundendienst : kundenservice@alicesgarden.de



FR

Donnez ou recyclez
vos meubles.



Association

ou



Magasin

ou



Déchèterie

<https://quefairedemesdechets.fr>

IDRES5SH

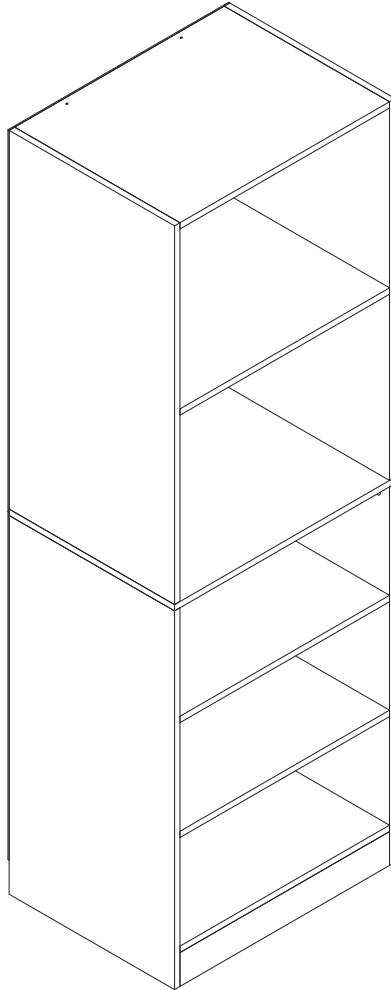

FRANÇAIS

Conseils d'entretien.....	6
Conseils d'utilisation.....	7
Avertissements.....	8
Garantie.....	9
Montage.....	10

**IMPORTANT, À CONSERVER
POUR CONSULTATION ULTÉRIEURE :
À LIRE ATTENTIVEMENT**

ESPAÑOL

Instrucciones de mantenimiento.....	6
Instrucciones de uso.....	7
Advertencia.....	8
Garantía.....	9
Montaje.....	10

**IMPORTANTE, CONSÉRVELO
PARA FUTURAS REFERENCIAS:
LEA ATENTAMENTE**

ENGLISH

Directions for use.....	6
Directions for use.....	7
Warning.....	8
Warranty.....	9
Assembly.....	10

**IMPORTANT, RETAIN FOR FUTURE
REFERENCE: PLEASE READ
CAREFULLY**

NEDERLANDS

Onderhoud.....	6
Gebruiksaanwijzingen	7
Waarschuwingen	8
Garantie.....	9
Montage.....	10

**BELANGRIJK, BEWAAR VOOR
TOEKOMSTIGE REFERENTIE:
ZORGVULDIG LEZEN**

PORTUGUÊS

Instruções para manutenção	6
Instruções de utilização	7
Advertência.....	8
Garantia.....	9
Assembleia.....	10

**IMPORTANTE, CONSERVE A
REFERÊNCIA DA FATURA:
LEIA CUIDADOSAMENTE**

ITALIANO

Consigli per la manutenzione	6
Consigli per l'uso	7
Avvertenze.....	8
Garanzia.....	9
Montaggio.....	10

**IMPORTANTE, CONSERVARE PER
ULTERIORI CONSULTAZIONI:
LEGGERE ATTENTAMENTE**

DEUTSCH

Pflegehinweis	6
Anwendungen	7
Warnhinweise	8
Garantie	9
Montage	10

**WICHTIG, FÜR SPÄTEREN
GEBRAUCH AUFBEWAHREN:
AUFMERKSAM LESEN**



Garantie : 2 ans
Garantía : 2 años
Warranty: 2 years
Garantie: 2 jaar
Garantia: 2 anos
Garanzia : 2 anni
Garantie: 2 Jahre



Destiné à un usage domestique
Destinado a un uso doméstico
For domestic use only
Bestemd voor huishoudelijk gebruik
Para uso doméstico
Destinato ad un uso domestico
Für den Haushaltsgebrauch vorgesehen



Attention : risques de blessures
Cuidado : riesgo de lesión
Warning : risk of injuries
Waarschuwing: risico op verwondigen
Cuidado: risco de ferimentos
Attenzione : rischio infortunio
Warnung: Verletzungsgefahr



Poids maximal : 50 kg
Peso máximo : 50 kg
Maximum weight: 50 kg
Maximale gewicht: 50 kg
Peso máximo: 50 kg
Peso massimo: 50 kg
Maximales gewicht: 50 kg

CONSEILS D'ENTRETIEN / INSTRUCCIONES DE MANTENIMIENTO / DIRECTIONS FOR USE / ONDERHOUD / INSTRUÇÕES DE UTILIZAÇÃO / CONSIGLI PER LA MANUTENZIONE / PFLEFEBINWELS

FR

Dépoussiérer régulièrement avec un chiffon propre, doux et sec.
Proscrire tout abrasif et produits acides. Ne jamais employer de solvants.

ES

Quitar el polvo regularmente con un paño limpio, suave y seco.
No utilice productos abrasivos o ácidos. No utilice nunca disolventes de limpieza.

EN

Regularly dust with a clean, soft and dry cloth.
Do not use any abrasive or acidic products. Never use cleaning solvents.

NL

Stof regelmatig af met een schone, zachte en droge doek.
Sluit alle schurende en zure producten uit. Gebruik nooit oplosmiddelen

PT

Pó regularmente com um espanador limpo, macio e seco.
Proibir qualquer esfregão e produtos ácidos. Nunca utilizar solvente de limpeza.

IT

Spolverare regolarmente con un panno pulito, morbido e asciutto.
Non usare prodotti abrasivi o acidi. Non usare mai solventi.

DE

Regelmäßig mit einem sauberen, weichen und trockenen Tuch abstauben.
Keinesfalls abrasive und ätzende Reinigungsprodukte anwenden. Verwenden Sie niemals Lösungsmittel.

CONSEILS D'UTILISATION / INSTRUCCIONES DE USO / DIRECTIONS FOR USE / GEBRUIKSIINSTRUCTIES / INSTRUÇÕES DE UTILIZAÇÃO / CONSIGLI PER L'USO / ANWENDUNGS

FR

Pour des raisons de stabilité, et afin de préserver les pas et les vis d'un serrage de travers, impératif d'assembler manuellement tous les éléments, et de serrer toutes les vis à la main dans un premier temps. Une fois l'assemblage terminé, vous pouvez procéder au serrage de la visserie de manière plus ferme.

Attention, ne pas s'asseoir sur le produit. En effet, cela peut entraîner une dégradation du produit, voire des blessures, n'entrant pas dans le cadre de la garantie.

ES

Para garantizar la estabilidad y evitar que las roscas de los tornillos se deformen, es imprescindible empezar por montar y atornillar cada pieza a mano. Una vez completado el montaje, se puede proceder a apretar los tornillos con mayor firmeza.

No se siente sobre el producto. De lo contrario, el producto podría resultar dañado o incluso sufrir lesiones, lo que no está cubierto por la garantía.

EN

To ensure stability and in order to prevent the screw threads from becoming deformed, it is essential to start by assembling and screwing in each piece by hand. Once the assembly is complete, you can proceed to tighten the screws more firmly.

Do not sit on the product. Doing so may result in damage to the product or even injury, which is not covered by the warranty.

NL

Omwille van de stabiliteit en om doordraaien te voorkomen, is het van cruciaal belang om alle elementen handmatig te monteren en alle schroeven in eerste instantie met de hand aan te halen. Na de montage kunt u de schroeven steviger vastzetten.

Ga niet op het product zitten. Dit kan leiden tot schade aan het product of zelfs letsel, wat niet onder de garantie valt.

PT

Por razões de estabilidade e a fim de preservar o alinhamento da estrutura, é imperativo montar cada peça à mão em primeiro lugar. Uma vez terminada a montagem, é possível proceder ao aperto firme do parafuso.

Não se sentar sobre o produto. Fazê-lo pode resultar em danos no produto ou mesmo em ferimentos, que não estão cobertos pela garantia.

IT

Per ragioni di stabilità e per proteggere le filettature delle viti da un errato serraggio, è imperativo assemblare tutti gli elementi a mano e stringere tutte le viti a mano all'inizio. Una volta completato il montaggio, le viti possono essere serrate più saldamente.

Non sedersi sul prodotto. Ciò potrebbe causare danni al prodotto o addirittura lesioni, che non sono coperte dalla garanzia.

DE

Aus Stabilitätsgründen und um ein Überziehen der Gewinde zu verhindern, müssen unbedingt alle Komponenten manuell zusammengebaut und alle Schrauben zuerst von Hand angezogen werden. Sobald die Montage abgeschlossen ist, können Sie die Hardware fester anziehen.

Setzen Sie sich nicht auf das Produkt. Dies kann nämlich zu einer Beschädigung des Produkts oder sogar zu Verletzungen führen, die nicht unter die Garantie fallen.

AVERTISSEMENTS / WAARSCHUWINGEN / WARNHINWEISE / WARNING / ADVERTENCIA / ADVERTÊNCIA / AVVERTENZE

FR

ATTENTION : Risque de blessure grave ou mortelle en cas de basculement du meuble. Pour éviter que le meuble ne bascule, il faut le fixer au mur de façon permanente à l'aide des pièces incluses pour la fixation. Les vis et chevilles ne sont pas incluses car leur choix dépend du matériau du mur sur lequel est fixé le meuble. Utilisez des vis et chevilles adaptées au matériau du mur.

ES

PRECAUCIÓN: Riesgo de lesiones mortales o graves en caso de que el mueble se vuelque. Para evitar que el mueble se caiga, debe fijarlo a la pared de forma permanente con las piezas de fijación incluidas. Los tornillos y tacos no están incluidos, ya que la selección de estas piezas depende del material de la pared en la que se fijará el mueble. Utilice los tornillos y tacos adecuados para el material de su pared.

EN

Caution: Risk of mortal or serious injuries in case of the furniture toppling over. To avoid the furniture falling, you must fix it to the wall permanently with the included fixing pieces. Screws and dowels are not included, as the selection of these parts is dependent on the wall material that the furniture will be fixed to. Use the correct screws and dowels for your wall material.

NL

WAARSCHUWING : Wanneer meubels omvallen, kaner ernstig of levens bedreigend belemmingsletsel ontstaan. Om te voorkomen dat dit meubel omvalt, dient dit permanent met de meegeleverde wandbevestigingen aan de wand te worden bevestigd. Bevestigingsbeslag voor de wand is niet inbegrepen, aangezien verschillende soorten bevestigingsbeslag dat geschikt is voor de wanden in je huis.

PT

CUIDADO: Riscos de ferimentos mortais ou graves em caso de tombamento do mobiliário. Para evitar o tombamento do mobiliário, é necessário fixá-lo permanentemente na parede com as peças de fixação incluídas. Os parafusos e cavilhas não estão incluídos, a sua escolha depende do material da parede em que o mobiliário será fixado. Utilizar parafusos e cavilhas adaptados de acordo com o material da parede.

IT

ATTENZIONE: rischio di lesioni gravi o morte se il mobile si rovescia. Per evitare che i mobili si ribaltino, devono essere fissati in modo permanente alla parete utilizzando gli elementi di fissaggio inclusi. Viti e tasselli non sono inclusi perché la loro scelta dipende dal materiale del muro a cui il mobile è attaccato. Usare viti e tasselli adatti al materiale della parete.

DE

ACHTUNG : Wenn Möbelstücke umkippen, können ernste oder lebensgefährliche Verletzungen durch Einklemmen die Folge sein. Um zu verhindern, dass dieses Möbelstück umkippt, muss es mit der beigegepackten Vorrichtung zur Wandbefestigung fest an der Wand verankert werden. Beschläge für die Wandbefestigung sind nicht beigegepackt, da sie von der Beschaffenheit der Wand und des Untergrundmaterials abhängig sind. Befestigungsbeschläge.

GARANTIE / GARANTÍA / WARRANTY / GARANTIA / GARANZIA

FR

Alice's Garden garantit toutes les pièces du produit contre tout vice de fabrication et de matériau pendant une période de 2 ans à compter de la date de réception par le consommateur.

LISTE DES EXCLUSIONS DE GARANTIE

- Le non-respect des conseils d'utilisation du constructeur.

ES

Alice's Garden garantiza que todas las piezas del producto están libres de defectos de fabricación y materiales durante un periodo de 2 años a partir de la fecha de recepción por parte del consumidor.

LISTA DE EXCLUSIONES DE LA GARANTÍA

- No seguir las instrucciones de uso del fabricante.

EN

Alice's Garden warrants all parts of the product to be free from defects in workmanship and materials for a period of 2 years from the date of receipt by the consumer.

LIST OF WARRANTY EXCLUSIONS

- Failure to follow the manufacturer's instructions for use.

NL

Alice's Garden garandeert dat alle onderdelen van het product vrij zijn van fabricage- en materiaalfouten gedurende een periode van 2 jaar vanaf de datum van ontvangst door de consument.

LIJST VAN GARANTIE-UITSLUITINGEN

- Het niet volgen van de gebruiksaanwijzing van de fabrikant.

PT

Alice's Garden garante que todas as partes do produto estão livres de defeitos de fabrico e materiais durante um período de 2 anos a partir da data da sua recepção pelo consumidor.

LISTA DE EXCLUSÕES DE GARANTIA

- Não seguir as instruções de utilização do fabricante.

IT

Alice's Garden garantisce che tutte le parti del prodotto sono prive di difetti di lavorazione e di materiali per un periodo di 2 anni dalla data di ricevimento da parte del consumatore.

ELENCO DELLE ESCLUSIONI DALLA GARANZIA

- Mancata osservanza delle istruzioni d'uso del produttore.

DE

Alice's Garden garantiert für einen Zeitraum von zwei Jahren ab dem Datum des Erhalts durch den Verbraucher, dass alle Teile des Produkts frei von Verarbeitungs- und Materialfehlern sind.

LISTE DER GARANTIEAUSSCHLÜSSE

- Die Nichtbeachtung der Gebrauchshinweise des Herstellers.

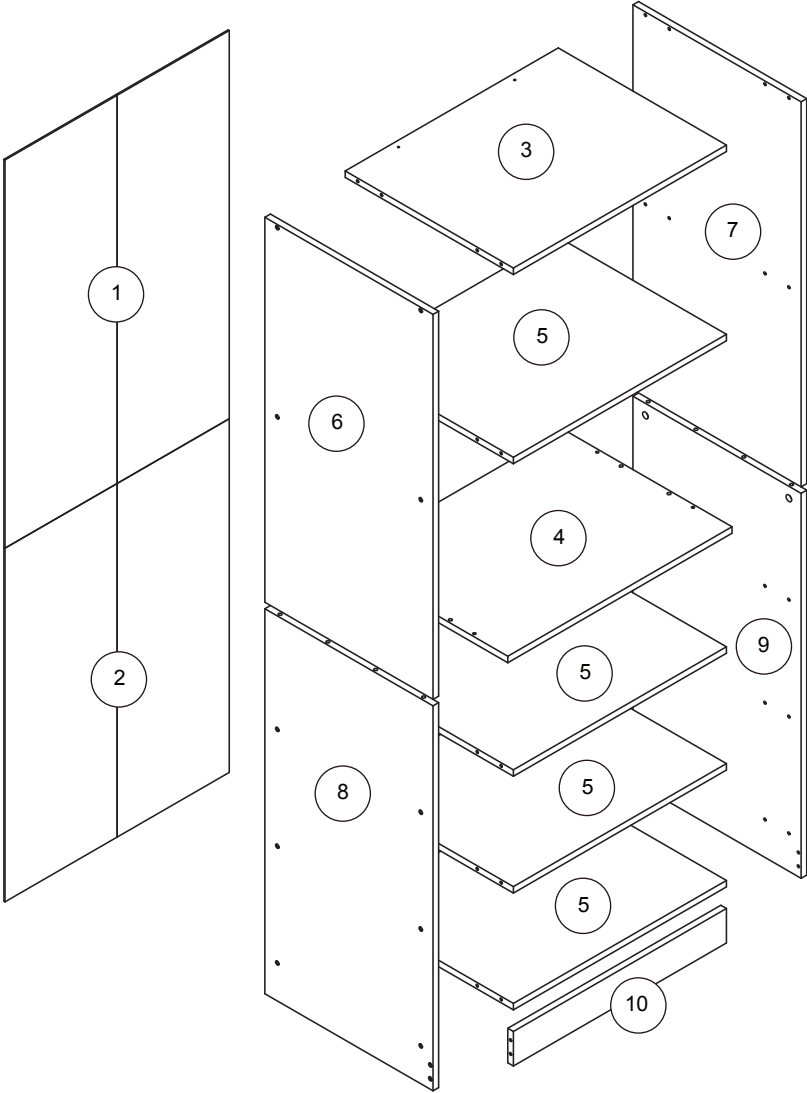

A



6x35mm

× 4

B



15x10mm

× 4

C



4x35mm

× 28

D



3x14mm

× 34

E



6x30mm

× 20

F



6x50mm

× 4

G



× 2

H



× 24

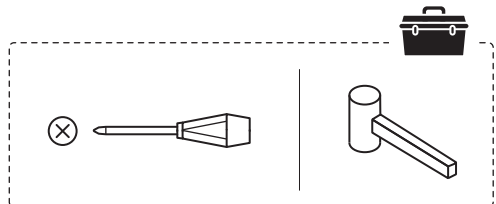

1

A x4
D x2
G x2

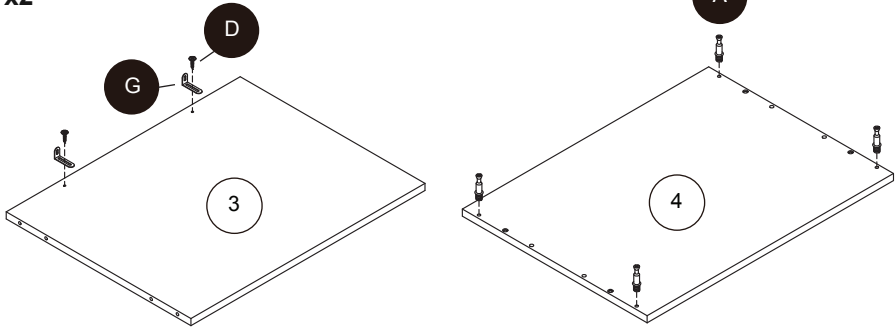

2

C x8
E x8
H x8

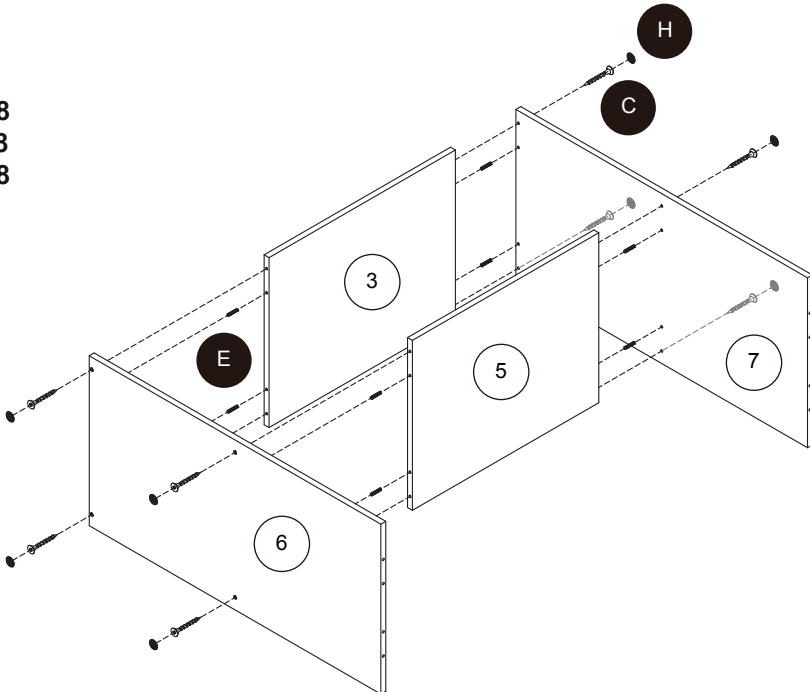

3

C x4
F x4

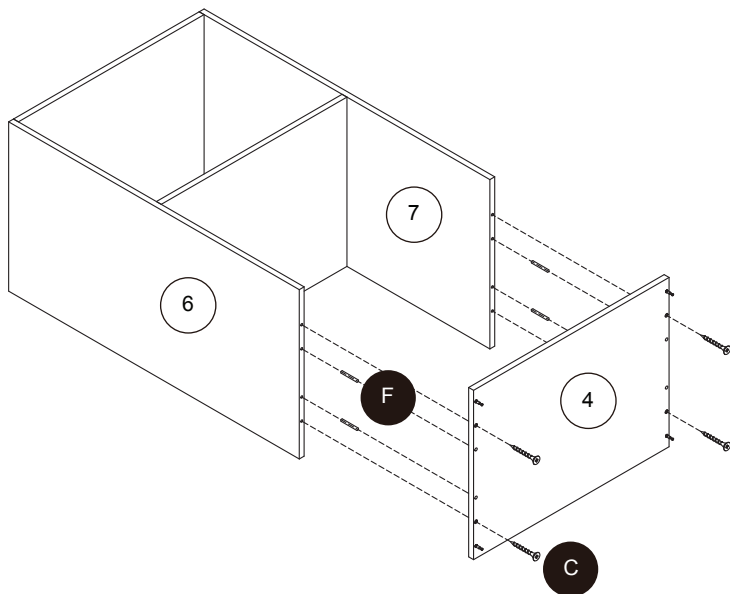

4

C x8
E x6
H x8

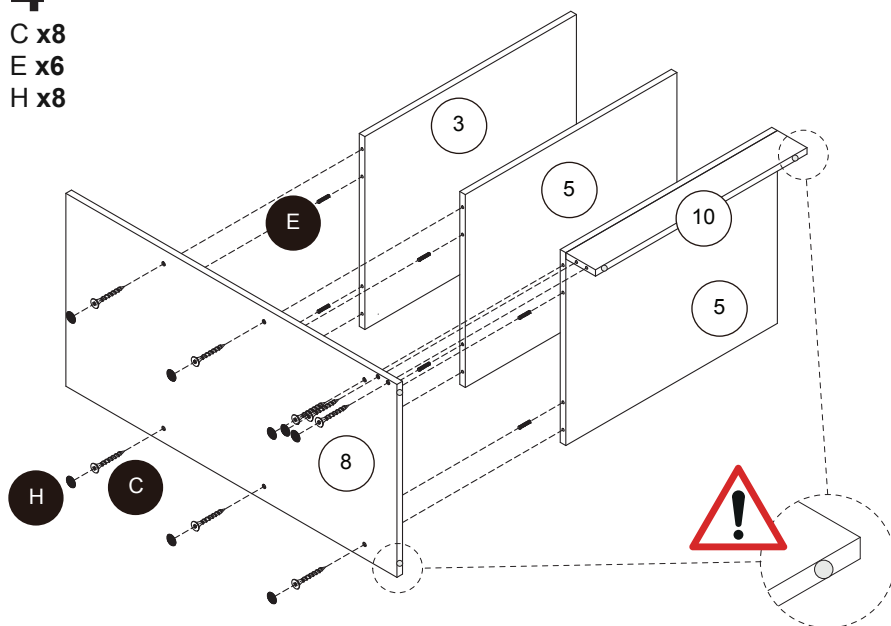

5

C x8

E x6

H x8

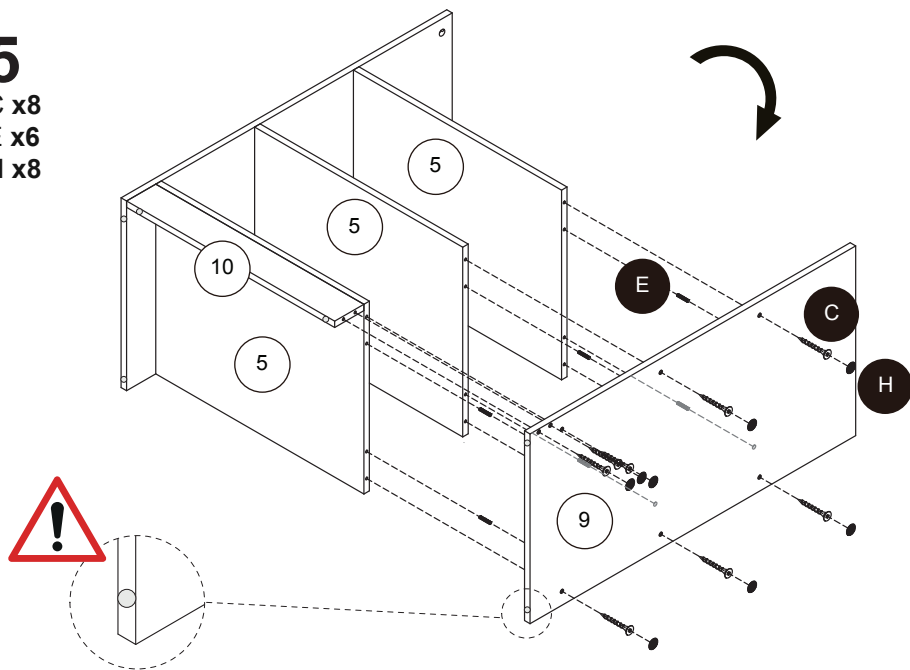

6

B x4

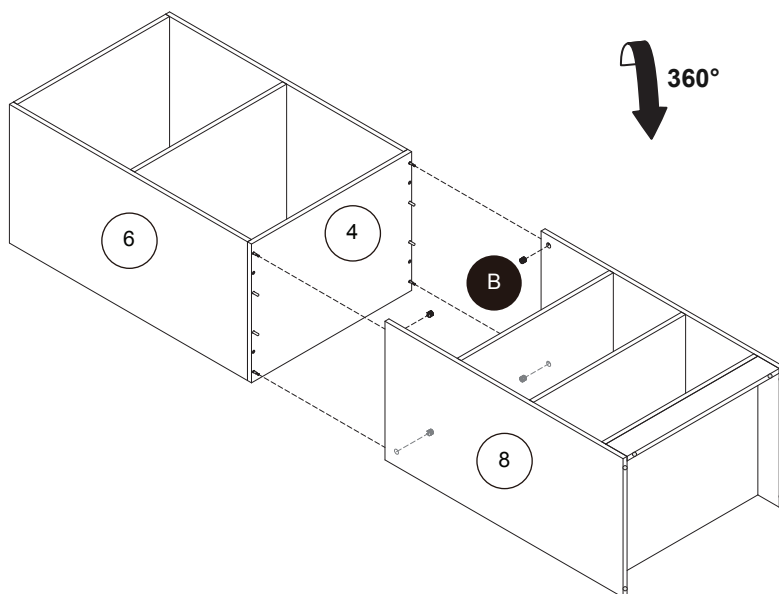

7

D x32

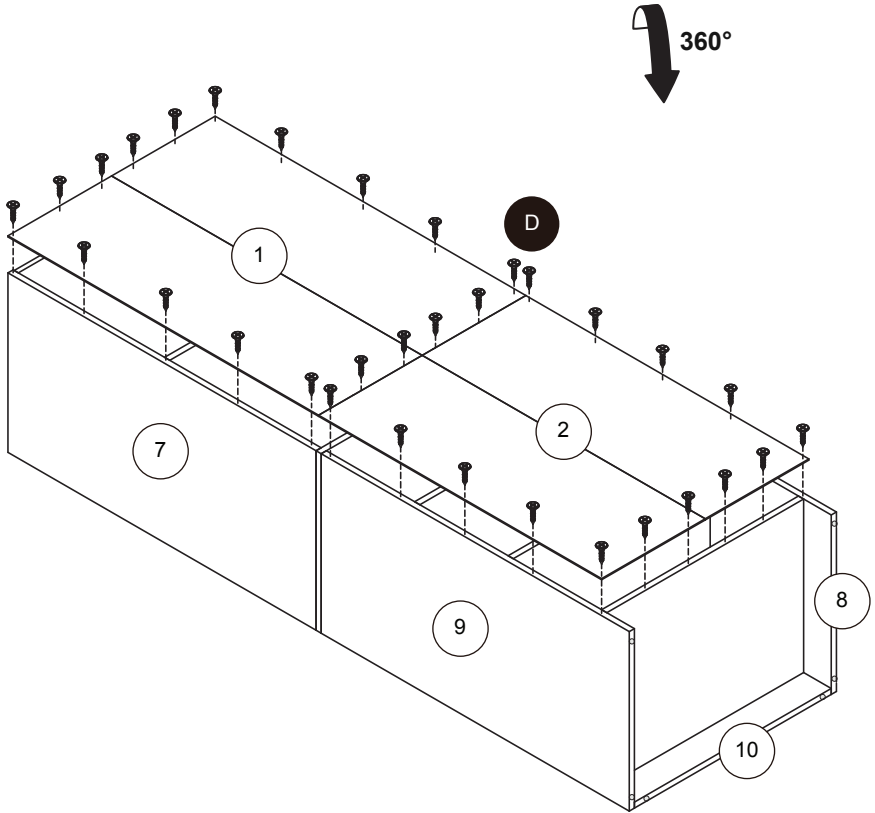

8

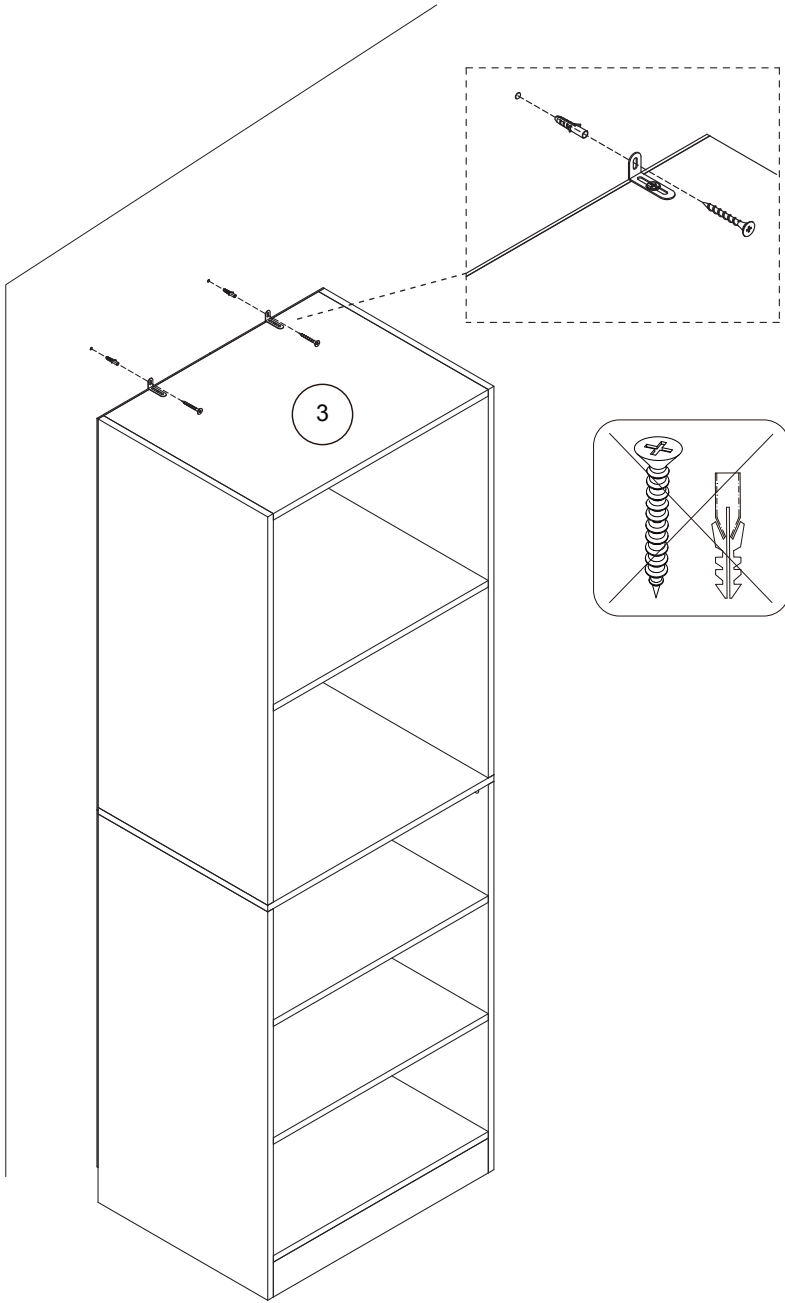

9

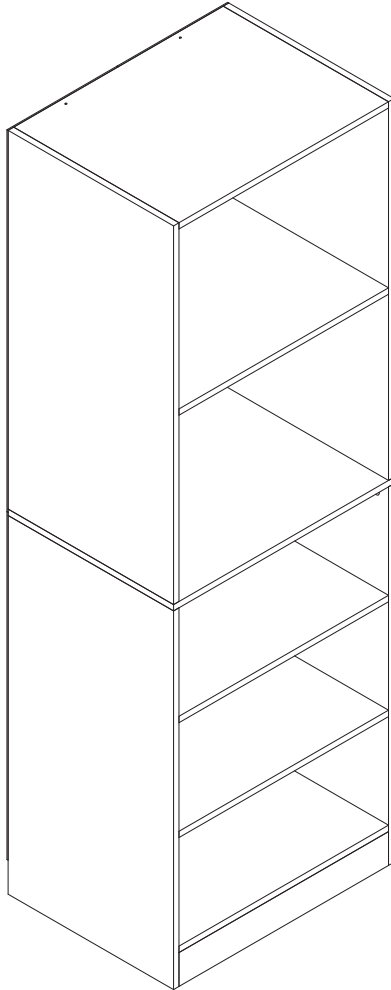

IMPORTÉ PAR WALIBUY SAS
270 avenue de l'Espace, 59118 WAMBRECHIES - FRANCE
Service après vente : sav.alicesgarden.fr - sav.alicesgarden.be

IMPORTADO POR WALIBUY SPAIN SL
Carrer de Mallorca 289, Entresuelo 2, 08037 BARCELONA - ESPAÑA
Servicio postventa : alicesgarden.es/cms/contacto

IMPORTED BY ALICE'S GARDEN UK LTD
23 Copenhagen Street, LONDON N10JB - UNITED KINGDOM
After sales service: alicesgarden.co.uk/cms/contact-us

INGEVOERD DOOR WALIBUY SAS
270 avenue de l'Espace, 59118 WAMBRECHIES - FRANKRIJK
After-sales : aftersales.alicesgarden.nl - aftersales.alicesgarden.be

IMPORTADO PARA WALIBUY SPAIN SL
Carrer de Mallorca 289, Entresuelo 2, 08037 BARCELONA - ESPAÑA
Serviço pós-venda : alicesgarden.pt/cms/contato

IMPORTATO DA WALIBUY ITALIA S.R.L
Via Torino 60, 20123 MILANO - ITALIA
Contatto : contatto@alicesgarden.it

IMPORTED BY ALICE'S GARDEN OUTDOOR PTY LTD
135-153 New South Head Road, Edgecliff NSW 2027 - AUSTRALIA
Contact : service@alicesgarden.com.au

IMPORTIERT VON WALIBUY SAS
270 AVENUE DE L'ESPACE, 59118 WAMBRECHIES - FRANKREICH
Kundendienst : kundenservice@alicesgarden.de



FR

Donnez ou recyclez
vos meubles.



Association

ou



Magasin

ou



Déchèterie

<https://quefairedemesdechets.fr>

IDRESTRAIL

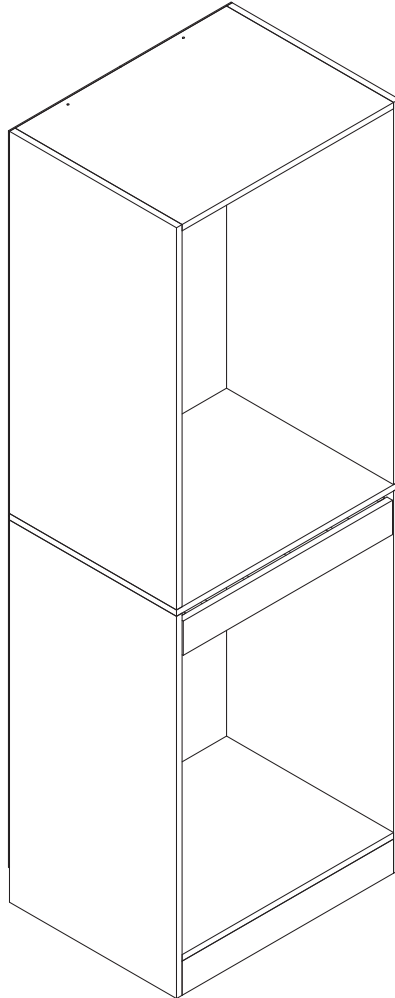

FRANÇAIS

Conseils d'entretien.....	6
Conseils d'utilisation.....	7
Avertissements.....	8
Garantie.....	9
Montage.....	10

**IMPORTANT, À CONSERVER
POUR CONSULTATION ULTÉRIEURE :
À LIRE ATTENTIVEMENT**

ESPAÑOL

Instrucciones de mantenimiento.....	6
Instrucciones de uso.....	7
Advertencia.....	8
Garantía.....	9
Montaje.....	10

**IMPORTANTE, CONSERVAR PARA FU-
TURAS CONSULTAS: LEER ATENTA-
MENTE**

ENGLISH

Directions for maintenance.....	6
Directions for use.....	7
Warning.....	8
Warranty.....	9
Assembly.....	10

**IMPORTANT, RETAIN FOR FUTURE
REFERENCE: PLEASE READ
CAREFULLY**

NEDERLANDS

Onderhoud.....	6
Gebruiksaanwijzing	7
Waarschuwingen	8
Garantie.....	9
Montage.....	10

**BELANGRIJK, BEWAAR VOOR
TOEKOMSTIGE REFERENTIE:
ZORGVULDIG LEZEN**

PORTUGUÊS

Instruções para manutenção	6
Instruções de utilização	7
Advertência.....	8
Garantia.....	9
Montagem.....	10

**IMPORTANTE, PARA CONSEGUIR FU-
TURO REFERÊNCIA: PARA LER COM
ATENÇÃO**

ITALIANO

Consigli per la manutenzione	6
Consigli per l'uso	7
Avvertenze.....	8
Garanzia.....	9
Montaggio.....	10

**IMPORTANTE, CONSERVARE PER
ULTERIORI CONSULTAZIONI:
LEGGERE ATTENTAMENTE**

DEUTSCH

Pflegehinweis	6
Verwendungstipps	7
Warnhinweise	8
Garantie.....	9
Montage.....	10

**WICHTIG, FÜR SPÄTEREN
GEBRAUCH AUFBEWAHREN:
AUFMERKSAM LESEN**



Garantie : 2 ans
Garantía : 2 años
Warranty: 2 years
Garantie: 2 jaar
Garantia: 2 anos
Garanzia : 2 anni
Garantie: 2 Jahre



Destiné à un usage domestique
Destinado a un uso doméstico
For domestic use only
Bestemd voor huishoudelijk gebruik
Para uso doméstico
Destinato ad un uso domestico
Für den Haushaltsgebrauch vorgesehen



Attention : risques de blessures
Cuidado : riesgo de lesión
Warning : risk of injuries
Waarschuwing: risico op verwondigen
Cuidado: risco de ferimentos
Attenzione : rischio infortunio
Warnung: Verletzungsgefahr



Poids maximal : 50 kg
Peso máximo : 50 kg
Maximum weight: 50 kg
Maximale gewicht: 50 kg
Peso máximo: 50 kg
Peso massimo: 50 kg
Maximales gewicht: 50 kg

CONSEILS D'ENTRETIEN / INSTRUCCIONES DE MANTENIMIENTO / DIRECTIONS FOR USE / ONDERHOUD / INSTRUÇÕES DE UTILIZAÇÃO / CONSIGLI PER LA MANUTENZIONE / PFLEFEHINWELS

FR

Dépoussiérer régulièrement avec un chiffon propre, doux et sec.
Proscrire tout abrasif et produits acides. Ne jamais employer de solvants.

ES

Quitar el polvo regularmente con un paño limpio, suave y seco.
No utilice productos abrasivos o ácidos. No utilice nunca disolventes de limpieza.

EN

Regularly dust with a clean, soft and dry cloth.
Do not use any abrasive or acidic products. Never use cleaning solvents.

NL

Stof regelmatig af met een schone, zachte en droge doek.
Sluit alle schurende en zure producten uit. Gebruik nooit oplosmiddelen.

PT

Pó regularmente com um espanador limpo, macio e seco.
Proibir qualquer esfregão e produtos ácidos. Nunca utilizar solvente de limpeza.

IT

Spolverare regolarmente con un panno pulito, morbido e asciutto.
Non usare prodotti abrasivi o acidi. Non usare mai solventi.

DE

Regelmäßig mit einem sauberen, weichen und trockenen Tuch abstauben.
Keinesfalls abrasive und ätzende Reinigungsprodukte anwenden. Verwenden Sie niemals Lösungsmittel.

CONSEILS D'UTILISATION / INSTRUCCIONES DE USO / DIRECTIONS FOR USE / GEBRUIKSIINSTRUCTIES / INSTRUÇÕES DE UTILIZAÇÃO / CONSIGLI PER L'USO / ANWENDUNGS

FR

Pour des raisons de stabilité, et afin de préserver les pas de vis d'un serrage de travers, il est impératif d'assembler manuellement tous les éléments, et de serrer toutes les vis à la main dans un premier temps. Une fois l'assemblage terminé, vous pouvez procéder au serrage de la visserie de manière plus ferme.

Attention, ne pas s'asseoir sur le produit. En effet, cela peut entraîner une dégradation du produit, voire des blessures, n'entrant pas dans le cadre de la garantie.

ES

Para garantizar la estabilidad y evitar que las roscas de los tornillos se deformen, es imprescindible empezar por montar y atornillar cada pieza a mano. Una vez completado el montaje, se puede proceder a apretar los tornillos con mayor firmeza.

No se siente sobre el producto. De lo contrario, el producto podría resultar dañado o incluso sufrir lesiones, lo que no está cubierto por la garantía.

EN

To ensure stability and in order to prevent the screw threads from becoming deformed, it is essential to start by assembling and screwing in each piece by hand. Once the assembly is complete, you can proceed to tighten the screws more firmly.

Do not sit on the product. Doing so may result in damage to the product or even injury, which is not covered by the warranty.

NL

Omwille van de stabiliteit en om doordraaien te voorkomen, is het van cruciaal belang om alle elementen handmatig te monteren en alle schroeven in eerste instantie met de hand aan te halen. Na de montage kunt u de schroeven steviger vastzetten.

Ga niet op het product zitten. Dit kan leiden tot schade aan het product of zelfs letsel, wat niet onder de garantie valt.

PT

Per ragioni di stabilità e per proteggere le filettature delle viti da un errato serraggio, è imperativo assemblare tutti gli elementi a mano e stringere tutte le viti a mano all'inizio.

Una volta completato il montaggio, le viti possono essere serrate più saldamente.

Não se sentar sobre o produto. Fazê-lo pode resultar em danos no produto ou mesmo em ferimentos, que não estão cobertos pela garantia.

IT

Per ragioni di stabilità e per proteggere le filettature delle viti da un errato serraggio, è imperativo assemblare tutti gli elementi a mano e stringere tutte le viti a mano all'inizio.

Una volta completato il montaggio, le viti possono essere serrate più saldamente.

Non sedersi sul prodotto. Ciò potrebbe causare danni al prodotto o addirittura lesioni, che non sono coperte dalla garanzia.

DE

Aus Stabilitätsgründen und um ein Überziehen der Gewinde zu verhindern, müssen unbedingt alle Komponenten manuell zusammengebaut und alle Schrauben zuerst von Hand angezogen werden. Sobald die Montage abgeschlossen ist, können Sie die Hardware fester anziehen.

Setzen Sie sich nicht auf das Produkt. Dies kann nämlich zu einer Beschädigung des Produkts oder sogar zu Verletzungen führen, die nicht unter die Garantie fallen.

AVERTISSEMENTS / WAARSCHUWINGEN / WARNHINWEISE / WARNING / ADVERTENCIA / ADVERTÊNCIA / AVVERTENZE

FR

ATTENTION : Risque de blessure grave ou mortelle en cas de basculement du meuble. Pour éviter que le meuble ne bascule, il faut le fixer au mur de façon permanente à l'aide des pièces incluses pour la fixation. Les vis et chevilles ne sont pas incluses car leur choix dépend du matériau du mur sur lequel est fixé le meuble. Utilisez des vis et chevilles adaptées au matériau du mur.

ES

PRECAUCIÓN: Riesgo de lesiones mortales o graves en caso de que el mueble se vuelque. Para evitar que el mueble se caiga, debe fijarlo a la pared de forma permanente con las piezas de fijación incluidas. Los tornillos y tacos no están incluidos, ya que la selección de estas piezas depende del material de la pared en la que se fijará el mueble. Utilice los tornillos y tacos adecuados para el material de su pared.

EN

Caution: Risk of mortal or serious injuries in case of the furniture toppling over. To avoid the furniture falling, you must fix it to the wall permanently with the included fixing pieces. Screws and dowels are not included, as the selection of these parts is dependent on the wall material that the furniture will be fixed to. Use the correct screws and dowels for your wall material.

NL

WAARSCHUWING : Wanneer meubels omvallen, kaner ernstig of levens bedreigend beklemmingsletsel ontstaan. Om te voorkomen dat dit meubel omvalt, dient dit permanent met de meegeleverde wandbevestigingen aan de wand te worden bevestigd. Bevestigingsbeslag voor de wand is niet inbegrepen, aangezien verschillende soorten bevestigingsbeslag dat geschikt is voor de wanden in je huis.

PT

CUIDADO: Riscos de ferimentos mortais ou graves em caso de tombamento do mobiliário. Para evitar o tombamento do mobiliário, é necessário fixá-lo permanentemente na parede com as peças de fixação incluídas. Os parafusos e cavilhas não estão incluídos, a sua escolha depende do material da parede em que o mobiliário será fixado. Utilizar parafusos e cavilhas adaptados de acordo com o material da parede.

IT

ATTENZIONE: rischio di lesioni gravi o morte se il mobile si rovescia. Per evitare che i mobili si ribaltino, devono essere fissati in modo permanente alla parete utilizzando gli elementi di fissaggio inclusi. Viti e tasselli non sono inclusi perché la loro scelta dipende dal materiale del muro a cui il mobile è attaccato. Usare viti e tasselli adatti al materiale della parete.

DE

ACHTUNG : Wenn Möbelstücke umkippen, können ernste oder lebensgefährliche Verletzungen durch Einklemmen die Folge sein. Um zu verhindern, dass dieses Möbelstück umkippt, muss es mit der beigegepackten Vorrichtung zur Wandbefestigung fest an der Wand verankert werden. Beschläge für die Wandbefestigung sind nicht beigegepackt, da sie von der Beschaffenheit der Wand und des Untergrundmaterials abhängig sind. Befestigungsbeschläge.

GARANTIE / GARANTÍA / WARRANTY / GARANTIA / GARANZIA

FR

Alice's Garden garantit toutes les pièces du produit contre tout vice de fabrication et de matériau pendant une période de 2 ans à compter de la date de réception par le consommateur.

LISTE DES EXCLUSIONS DE GARANTIE

- Le non-respect des conseils d'utilisation du constructeur.

ES

Alice's Garden garantiza que todas las piezas del producto están libres de defectos de fabricación y materiales durante un periodo de 2 años a partir de la fecha de recepción por parte del consumidor.

LISTA DE EXCLUSIONES DE LA GARANTÍA

- No seguir las instrucciones de uso del fabricante.

EN

Alice's Garden warrants all parts of the product to be free from defects in workmanship and materials for a period of 2 years from the date of receipt by the consumer.

LIST OF WARRANTY EXCLUSIONS

- Failure to follow the manufacturer's instructions for use.

NL

Alice's Garden garandeert dat alle onderdelen van het product vrij zijn van fabricage- en materiaalfouten gedurende een periode van 2 jaar vanaf de datum van ontvangst door de consument.

LIJST VAN GARANTIE-UITSLUITINGEN

- Het niet volgen van de gebruiksaanwijzing van de fabrikant.

PT

Alice's Garden garante que todas as partes do produto estão livres de defeitos de fabrico e materiais durante um período de 2 anos a partir da data da sua recepção pelo consumidor.

LISTA DE EXCLUSÕES DE GARANTIA

- Não seguir as instruções de utilização do fabricante.

IT

Alice's Garden garantisce che tutte le parti del prodotto sono prive di difetti di lavorazione e di materiali per un periodo di 2 anni dalla data di ricevimento da parte del consumatore.

ELENCO DELLE ESCLUSIONI DALLA GARANZIA

- Mancata osservanza delle istruzioni d'uso del produttore.

DE

Alice's Garden garantiert für einen Zeitraum von zwei Jahren ab dem Datum des Erhalts durch den Verbraucher, dass alle Teile des Produkts frei von Verarbeitungs- und Materialfehlern sind.

LISTE DER GARANTIEAUSSCHLÜSSE

- Die Nichtbeachtung der Gebrauchshinweise des Herstellers.

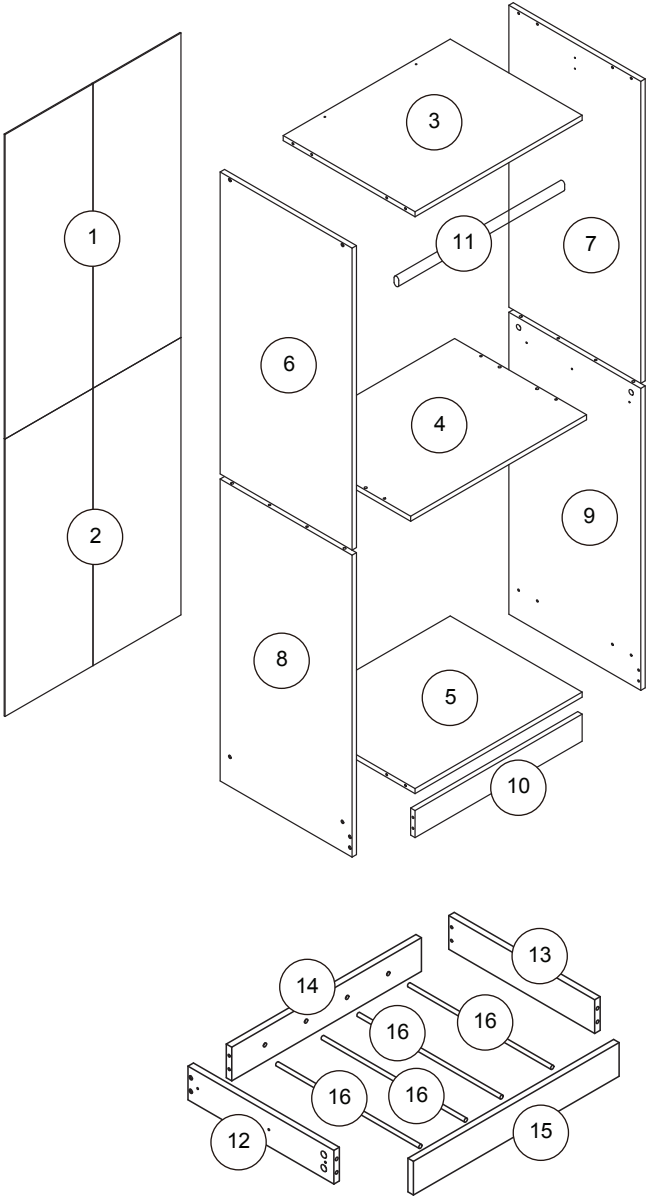

A



6x35mm

× 8

B



15x10mm

× 8

C



4x35mm

× 20

D



3x14mm

× 32

E



6x30mm

× 8

F



6x50mm

× 4

G



3,5x14mm

× 4

H



× 12

I



× 2

J



3x12mm

× 12

K



× 2

L

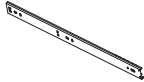

× 2

M



× 2

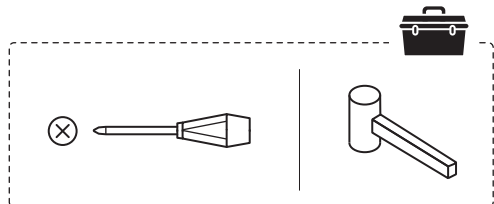

1

A x4
D x2
I x2

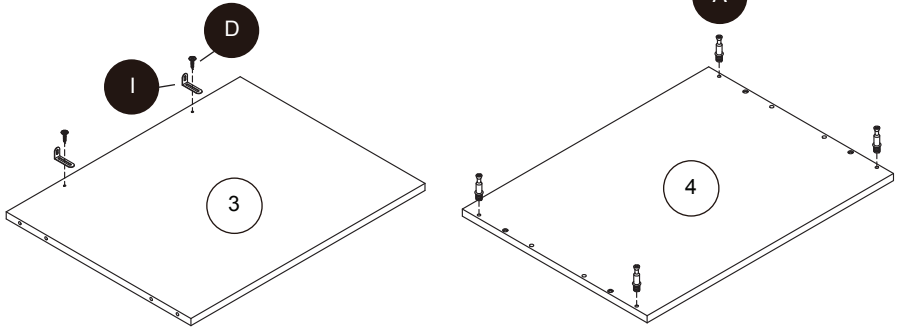

2

G x4
K x2

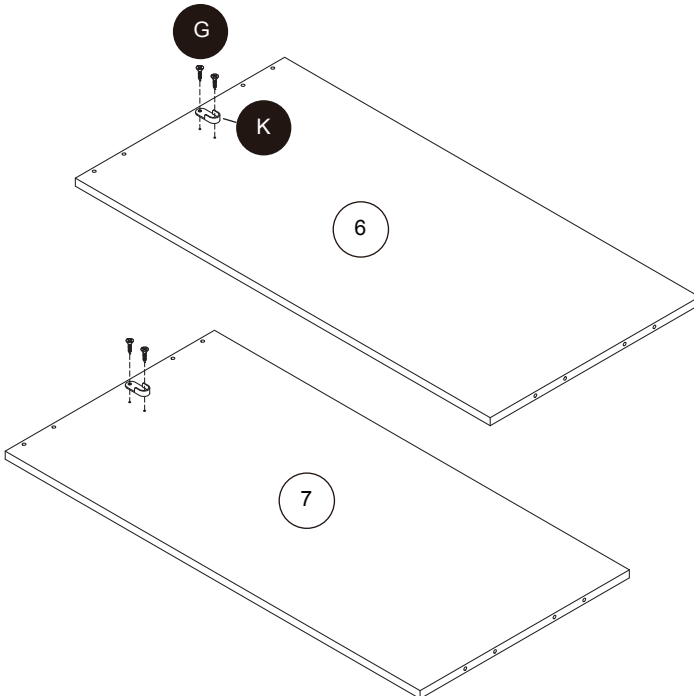

3

C x4
E x4
H x4

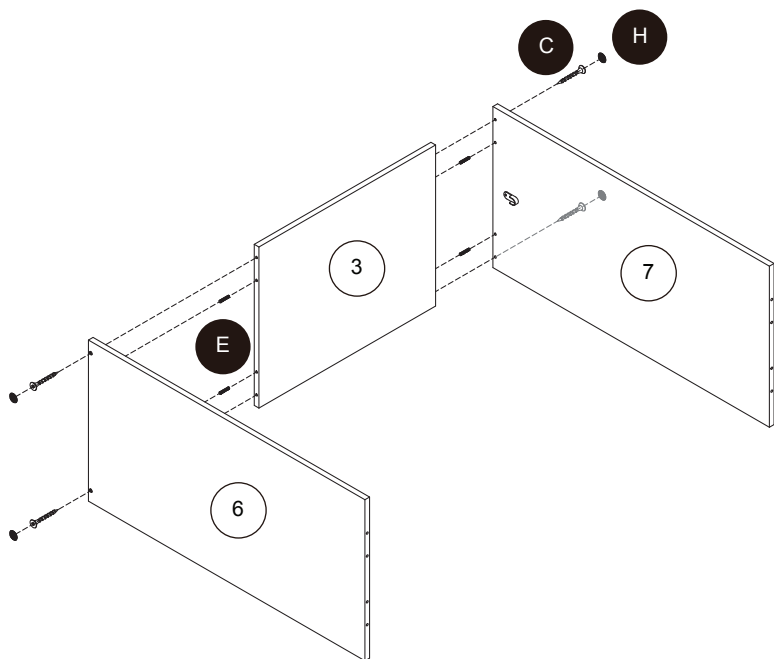

4

C x4
F x4

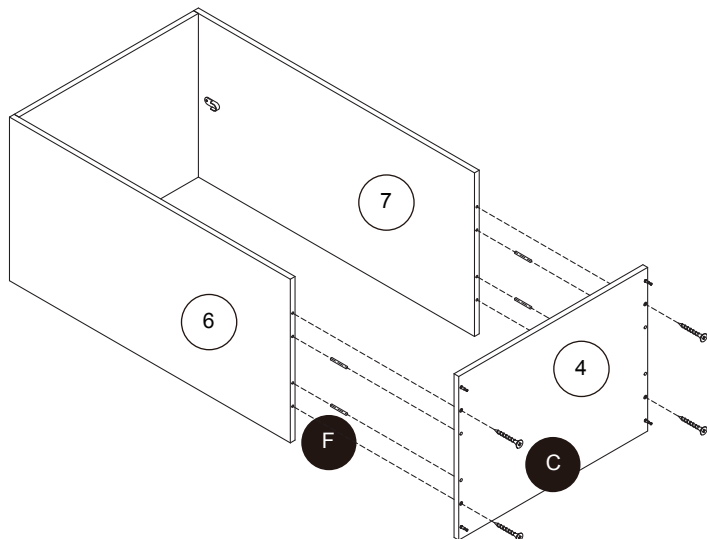

5

J x6
L x2

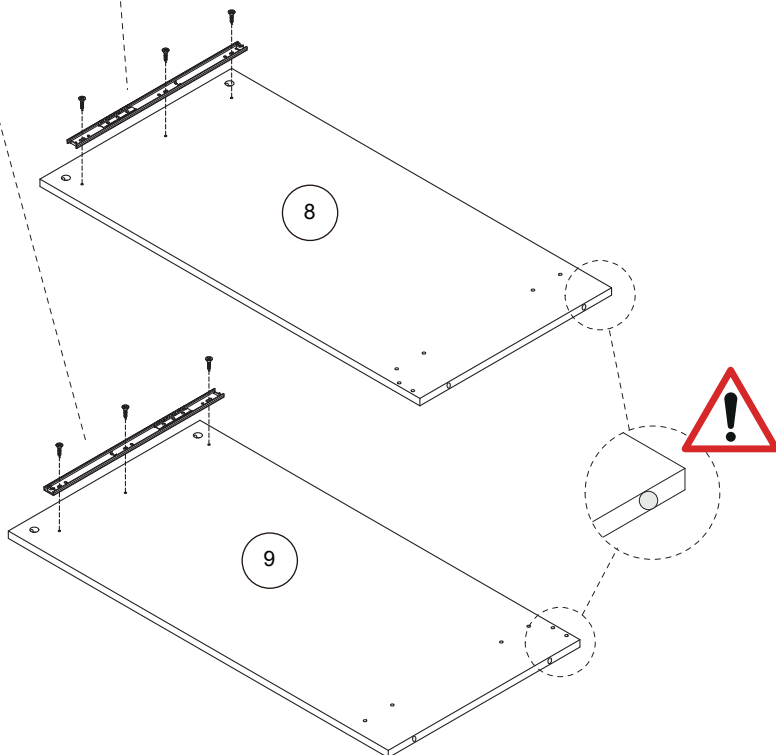
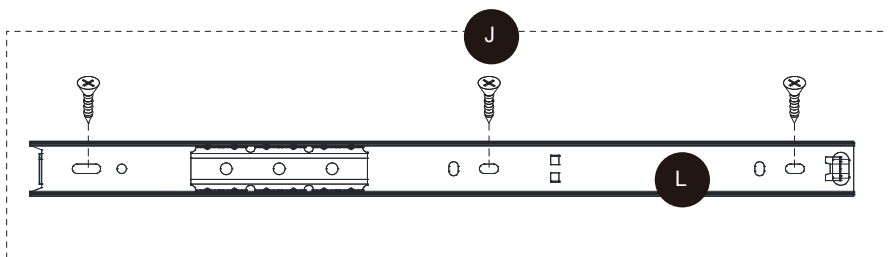
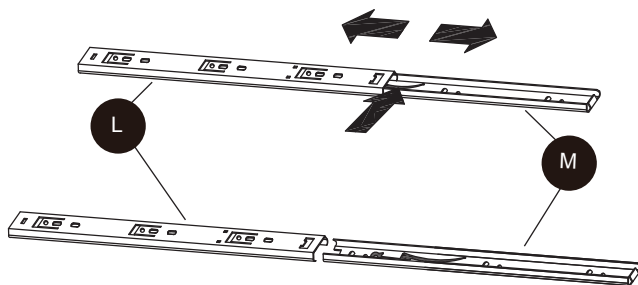

6

C x8
E x4
H x8

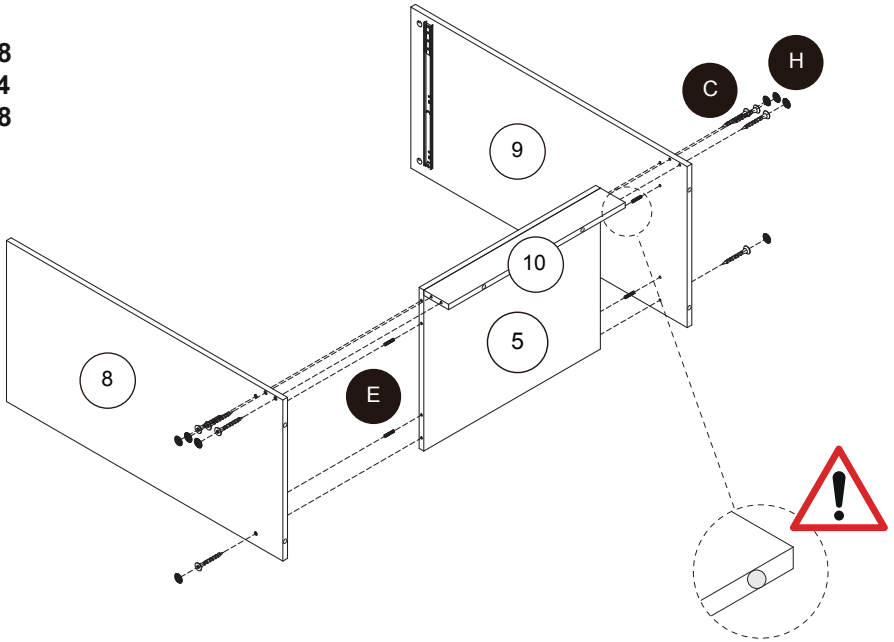

7

B x4

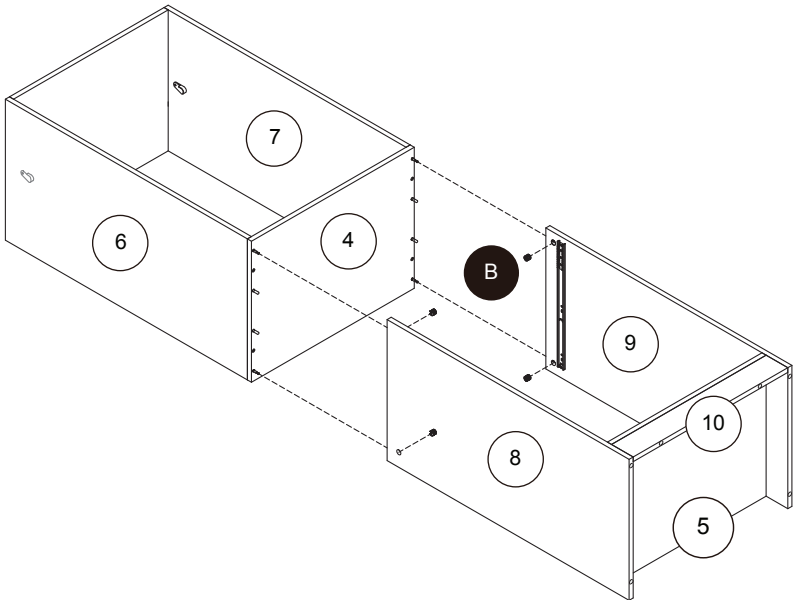

8

D x32

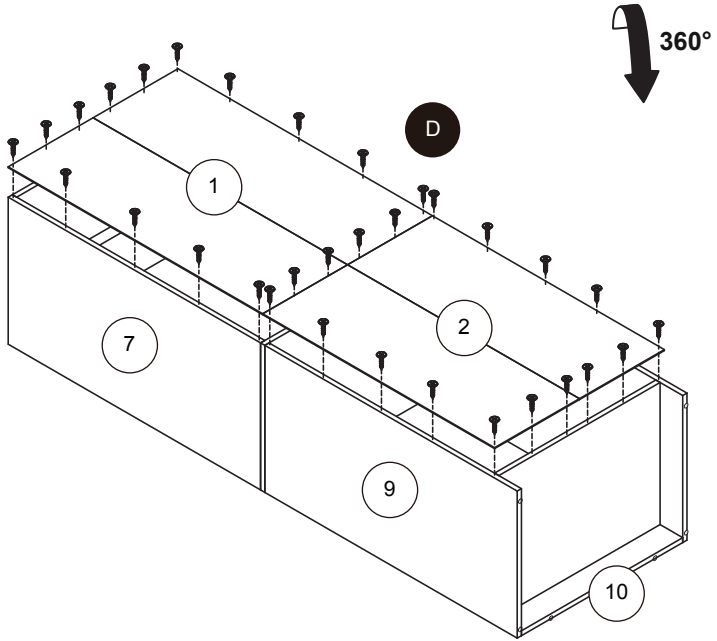

9

A x4
C x4

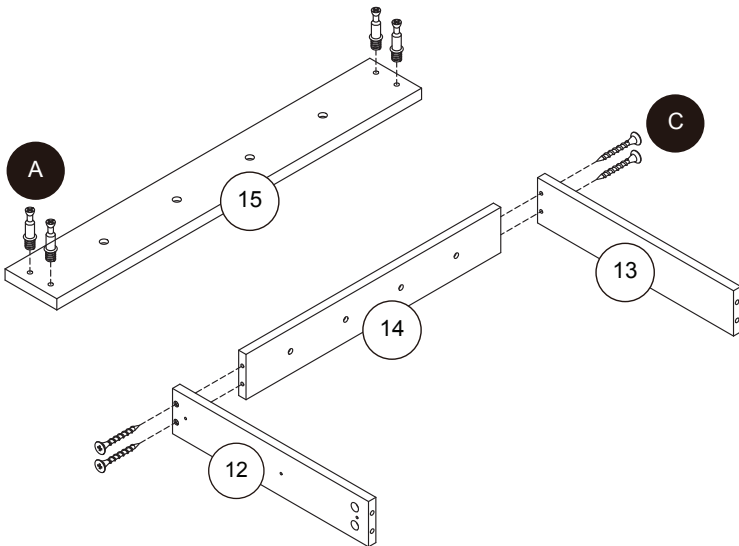

10

B x4

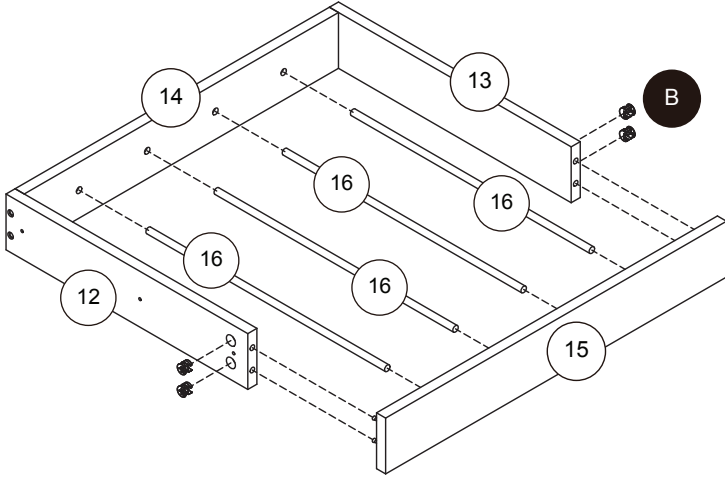

11

J x6

M x2

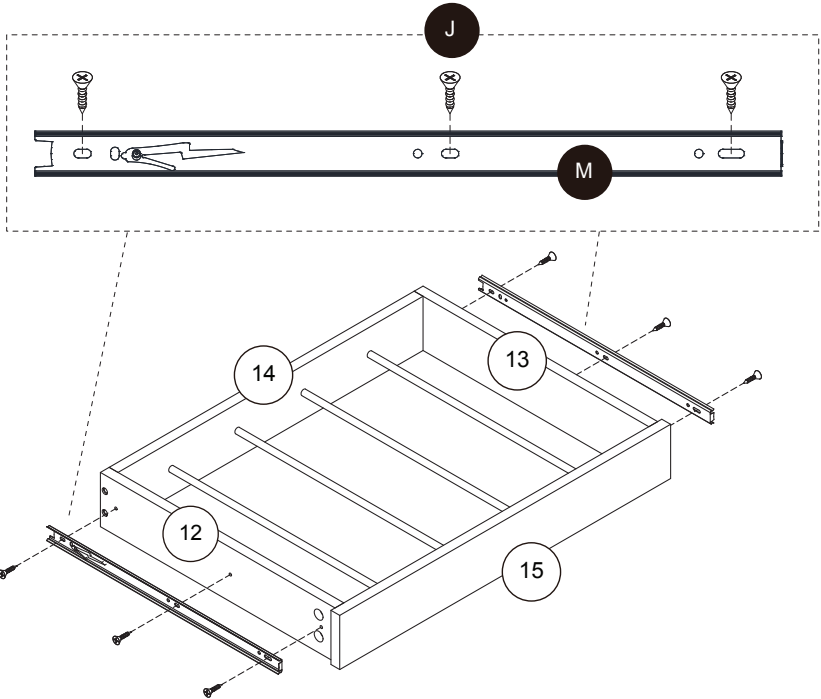

12

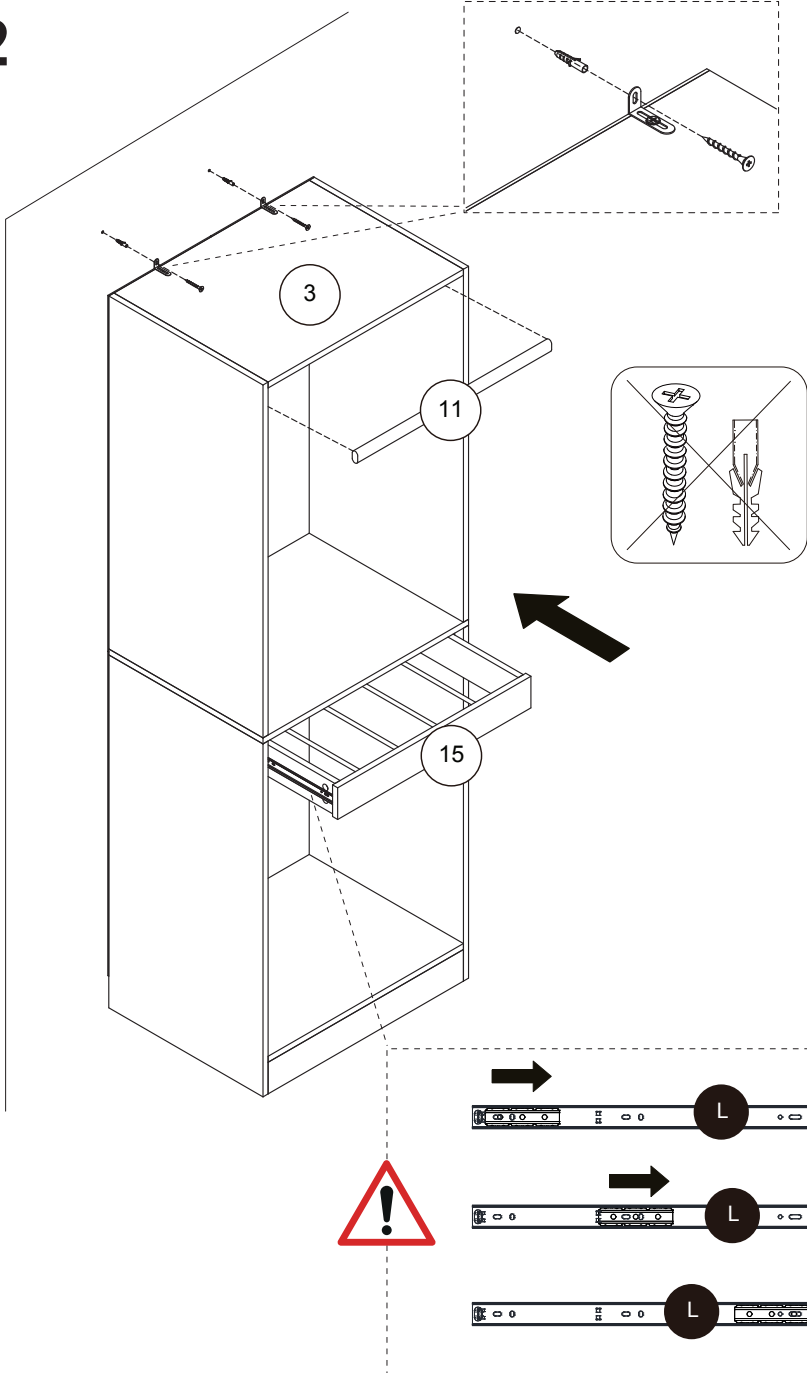

13

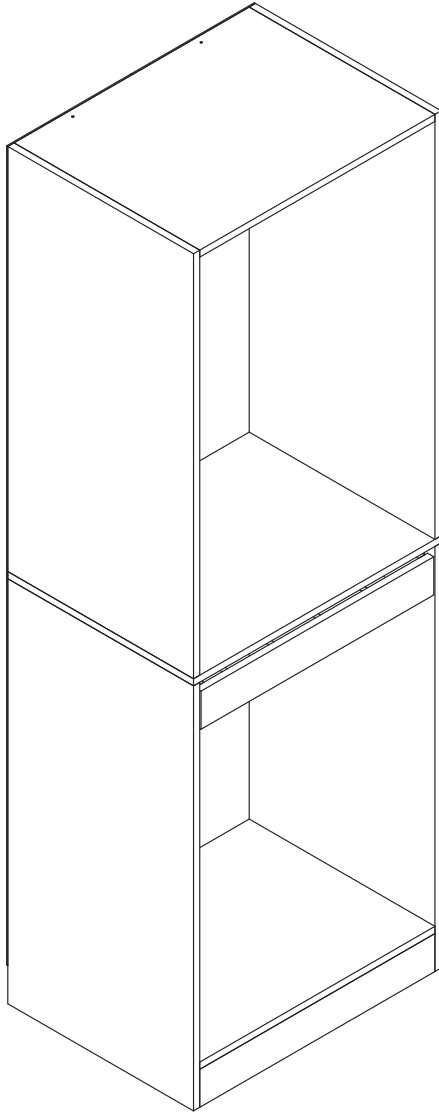

IMPORTÉ PAR WALIBUY SAS
270 avenue de l'Espace, 59118 WAMBRECHIES - FRANCE
Service après vente : sav.alicesgarden.fr - sav.alicesgarden.be

IMPORTADO POR WALIBUY SPAIN SL
Carrer de Mallorca 289, Entresuelo 2, 08037 BARCELONA - ESPAÑA
Servicio postventa : alicesgarden.es/cms/contacto

IMPORTED BY ALICE'S GARDEN UK LTD
23 Copenhagen Street, LONDON N10JB - UNITED KINGDOM
After sales service: alicesgarden.co.uk/cms/contact-us

INGEVOERD DOOR WALIBUY SAS
270 avenue de l'Espace, 59118 WAMBRECHIES - FRANKRIJK
After-sales : aftersales.alicesgarden.nl - aftersales.alicesgarden.be

IMPORTADO PARA WALIBUY SPAIN SL
Carrer de Mallorca 289, Entresuelo 2, 08037 BARCELONA - ESPAÑA
Serviço pós-venda : alicesgarden.pt/cms/contato

IMPORTATO DA WALIBUY ITALIA S.R.L
Via Torino 60, 20123 MILANO - ITALIA
Contatto : contatto@alicesgarden.it

IMPORTED BY ALICE'S GARDEN OUTDOOR PTY LTD
135-153 New South Head Road, Edgecliff NSW 2027 - AUSTRALIA
Contact : service@alicesgarden.com.au

IMPORTIERT VON WALIBUY SAS
270 AVENUE DE L'ESPACE, 59118 WAMBRECHIES - FRANKREICH
Kundendienst : kundenservice@alicesgarden.de



FR

Donnez ou recyclez
vos meubles.



Association

ou



Magasin

ou



Déchèterie

<https://quefairedemesdechets.fr>