

IKSCAM7

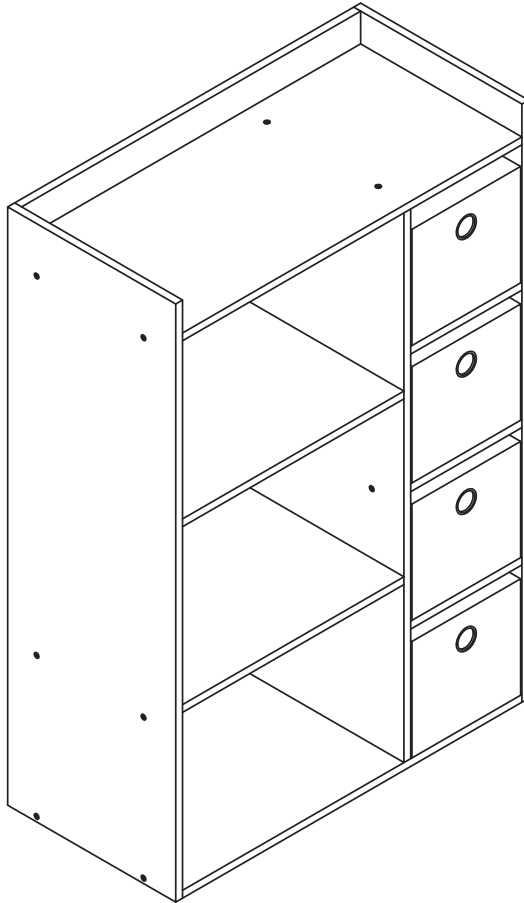

FRANÇAIS

Conseils d'entretien.....	6
Avertissements.....	7
Montage.....	9

**IMPORTANT, À CONSERVER
POUR CONSULTATION ULTÉRIEURE :
À LIRE ATTENTIVEMENT**

ESPAÑOL

Instrucciones de mantenimiento.....	6
Advertencia.....	7
Montaje.....	9

**IMPORTANTE, CONSERVAR PARA FU-
TURAS CONSULTAS: LEER ATENTA-
MENTE**

ENGLISH

Directions for maintenance.....	6
Warning.....	7
Assembly.....	9

**IMPORTANT, KEEP FOR FUTURE RE-
REFERENCE: READ CAREFULLY**

NEDERLANDS

Onderhoud.....	6
Waarschuwingen	7
Montage.....	9

**BELANGRIJK, BEWAAR VOOR
TOEKOMSTIGE REFERENTIE:
ZORGVULDIG LEZEN**

PORTUGUÊS

Instruções para manutenção	6
Advertência.....	7
Montagem.....	9

**IMPORTANTE, PARA CONSEGUIR FU-
TURO REFERÊNCIA: PARA LER COM
ATENÇÃO**

ITALIANO

Consigli per la manutenzione	6
Avvertenze.....	7
Montaggio.....	9

**IMPORTANTE, SI PREGA DI CONSER-
VARE PER RIFERIMENTO FUTURO:
SI PREGA DI LEGGERE
ATTENTAMENTE**

DEUTSCH

Pflegehinweis	6
Warnhinweise	8
Montage.....	9

**WICHTIG, FÜR SPÄTEREN
GEBRAUCH AUFBEWAHREN:
AUFMERKSAM LESEN**



Garantie : 2 ans
Garantía : 2 años
Warranty: 2 years
Garantie: 2 jaar
Garantia: 2 anos
Garanzia : 2 anni
Garantie: 2 Jahre



Destiné à un usage domestique
Destinado a un uso doméstico
Reserve for a domestic use
Bestemd voor huishoudelijk gebruik
Para uso doméstico
Destinato ad un uso domestico
Für den Haushaltsgebrauch vorgesehen



Attention : risques de blessures
Cuidado : riesgo de lesión
Warning : risk of injury
Waarschuwing: risico op verwondigen
Cuidado: risco de ferimentos
Attenzione : rischio infortunio
Warnung: Verletzungsgefahr



Poids maximal : 20 kg
Peso máximo : 20 kg
Maximum weight: 20 kg
Maximale gewicht: 20 kg
Peso máximo: 20 kg
Peso massimo: 20 kg
Maximales gewicht: 20 kg

CONSEILS D'ENTRETIEN / INSTRUCCIONES DE MANTENIMIENTO / DIRECTIONS FOR MAINTENANCE / ONDERHOUD / INSTRUÇÕES PARA MANUTENÇÃO / CONSIGLI PER LA MANUTENZIONE / PFLEFEHINWELS

FR

Dépoussiérer régulièrement avec un chiffon propre, doux et sec.
Proscrire tout abrasif et produits acides. Ne jamais employer de solvants

ES

Quitar el polvo regularmente con un paño limpio, suave y seco.
No utilice productos abrasivos o ácidos. No utilice nunca disolventes de limpieza

EN

Regularly dust with a clean, soft and dry cloth.
Do not use any abrasive or acidic products. Never use cleaning solvents

NL

Stof regelmatig af met een schone, zachte en droge doek.
Sluit alle schurende en zure producten uit. Gebruik nooit oplosmiddelen.

PT

Limpar o pó regularmente com um espanador limpo, macio e seco.
Proibir qualquer esfregão e produtos ácidos. Nunca utilizar solvente de limpeza.

IT

Spolverare regolarmente con un panno pulito, morbido e asciutto.
Non usare prodotti abrasivi o acidi. Non usare mai solventi.

DE

Regelmäßig mit einem sauberen, weichen und trockenen Tuch abstauben.
Keinesfalls: abrasive und ätzende Reinigungsprodukte anwenden. Verwenden Sie niemals Lösungsmittel.

AVERTISSEMENTS / WAARSCHUWINGEN / WARNHINWEISE / WARNING / ADVERTENCIA / ADVERTÊNCIA / AVVERTENZE

FR

ATTENTION : Risque de blessure grave ou mortelle en cas de basculement du meuble. Pour éviter que le meuble ne bascule, il faut le fixer au mur de façon permanente à l'aide des pièces incluses pour la fixation. Les vis et chevilles ne sont pas incluses car leur choix dépend du matériau du mur sur lequel est fixé le meuble. Utilisez des vis et chevilles adaptées au matériau du mur. Ne convient pas aux enfants de moins de 36 mois; risques d'asphyxie (les petits éléments sont susceptibles d'être avalés).

ES

PRECAUCIÓN: Riesgo de lesiones mortales o graves en caso de que el mueble se vuelque. Para evitar que el mueble se caiga, debe fijarlo a la pared de forma permanente con las piezas de fijación incluidas. Los tornillos y tacos no están incluidos, ya que la selección de estas piezas depende del material de la pared en la que se fijará el mueble. Utilice los tornillos y tacos adecuados para el material de su pared.

No apto para niños menores de 36 meses: riesgo de asfixia (podrían tragarse piezas pequeñas)

EN

Caution: Risk of mortal or serious injuries in case of the furniture toppling over. To avoid the furniture falling, you must fix it to the wall permanently with the included fixing pieces.

Screws and dowels are not included, as the selection of these parts is dependent on the wall material that the furniture will be fixed to. Use the correct screws and dowels for your wall material. Not suitable for children under 36 months old: risk of asphyxiation (small parts could be swallowed)

NL

WAARSCHUWING : Wanneer meubels omvallen, kaner ernstig of levens bedreigend beklemmingsletsel ontstaan. Om te voorkomen dat dit meubel omvalt, dient dit permanent met de meegeleverde wandbevestigingen aan de wand te worden bevestigd. Bevestigingsbeslag voor de wand is niet inbegrepen, aangezien verschillende soorten bevestigingsbeslag dat geschikt is voor de wanden in je huis.

Niet geschikt voor kinderen jonger dan 36 maanden; verstikkingsrisico (kleine onderdelen kunnen worden ingeslikt)

PT

CUIDADO: Riscos de ferimentos mortais ou graves em caso de tombamento do mobiliário. Para evitar o tombamento do mobiliário, é necessário fixá-lo permanentemente na parede com as peças de fixação incluídas. Os parafusos e cavilhas não estão incluídos, a sua escolha depende do material da parede em que o mobiliário será fixado. Utilizar parafusos e cavilhas adaptados de acordo com o material da parede.

Não adequado para crianças com menos de 36 meses: riscos de asfixia (as partes minúsculas podem ser reduzidas)

IT

ATTENZIONE: rischio di lesioni gravi o morte se il mobile si rovescia. Per evitare che i mobili si ribaltino, devono essere fissati in modo permanente alla parete utilizzando gli elementi di fissaggio inclusi. Viti e tasselli non sono inclusi perché la loro scelta dipende dal materiale del muro a cui il mobile è attaccato. Usare viti e tasselli adatti al materiale della parete.

Non adatto a bambini sotto i 36 mesi; rischio di asfissia (piccole parti possono essere ingerite)

ACHTUNG : Wenn Möbelstücke umkippen, können ernste oder lebensgefährliche Verletzungen durch Einklemmen die Folge sein. Um zu verhindern, dass dieses Möbelstück umkippt, muss es mit der beigepackten Vorrichtung zur Wandbefestigung fest an der Wand verankert werden. Beschläge für die Wandbefestigung sind nicht beigepackt, da sie von der Beschaffenheit der Wand und des Untergrundmaterials abhängig sind. Befestigungsbeschläge.

Nicht für Kinder unter 36 Monaten geeignet, da Erstickungsgefahr besteht (kleine Teile können verschluckt werden).

MONTAGE / MONTAJE / ASSEMBLY / MONTAGEM / MONTAGGIO

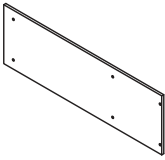
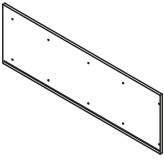
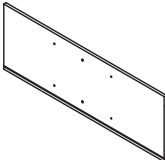
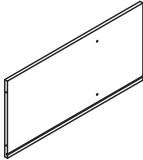
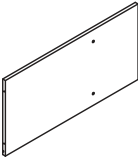
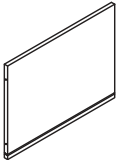
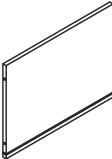
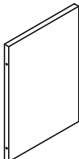
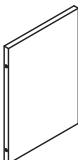
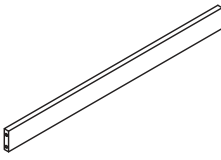
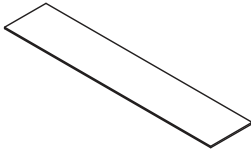
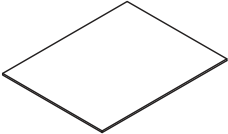
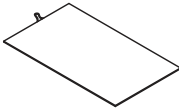
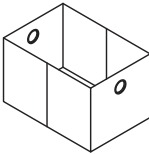
1		× 1	2		× 1
3		× 1	4		× 1
5		× 1	6		× 1
7		× 1	8		× 1
9		× 2	10		× 1
11		× 1	12		× 3
13		× 4	14		× 4

A



x 20

B



x 16

C



x 20

D



x 1

E



x 1

Outils nécessaires :

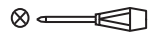

Tournevis

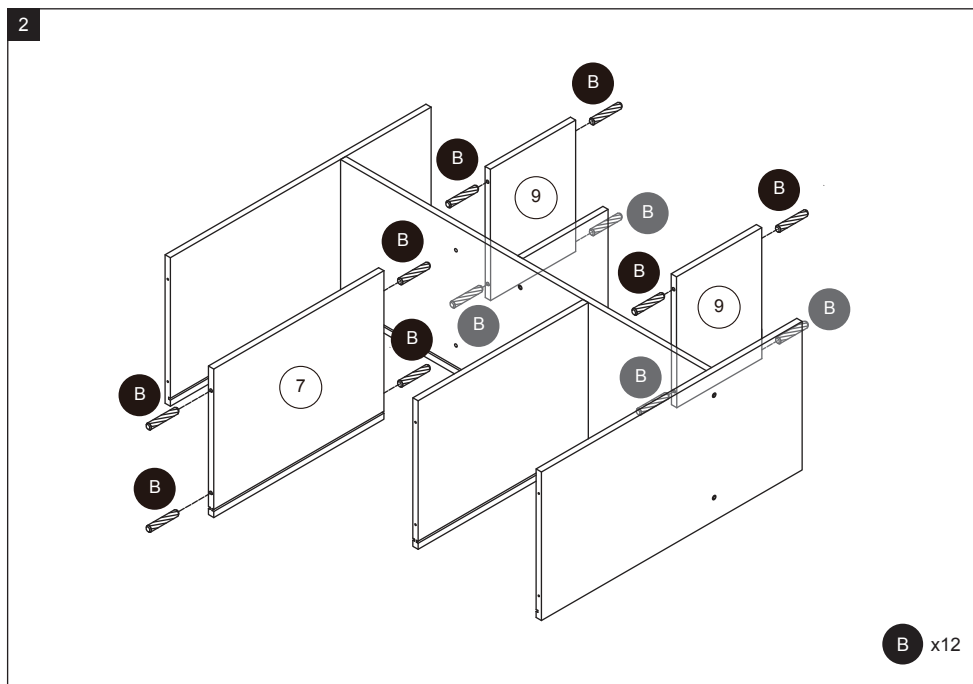
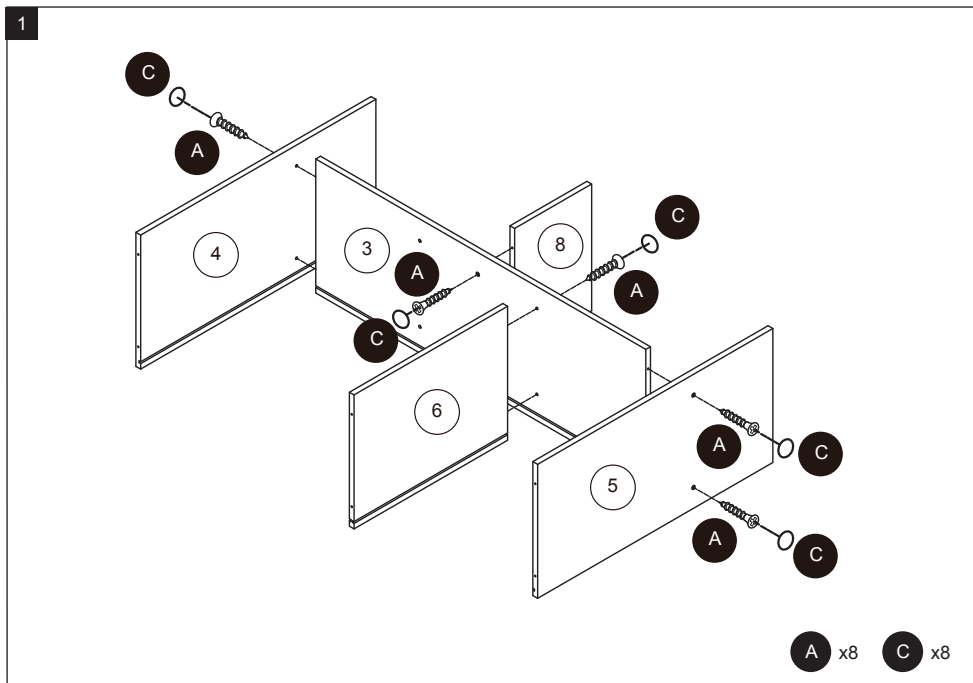

3

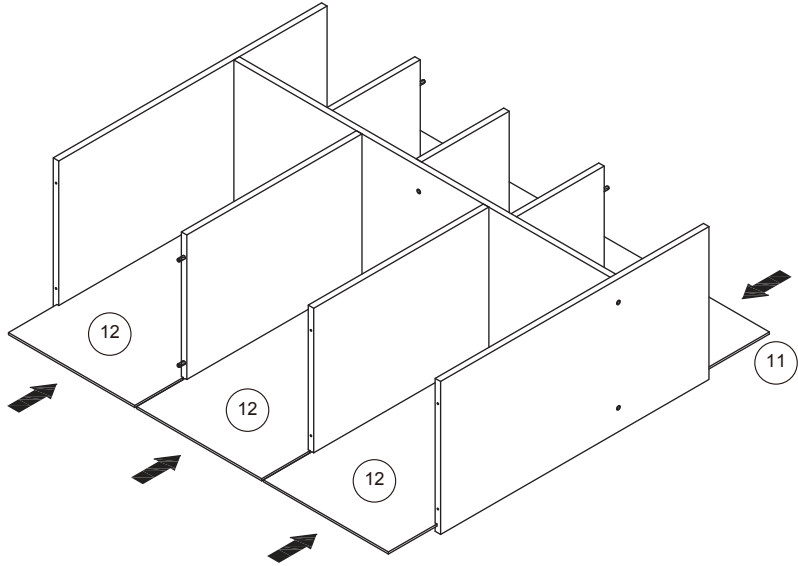

4

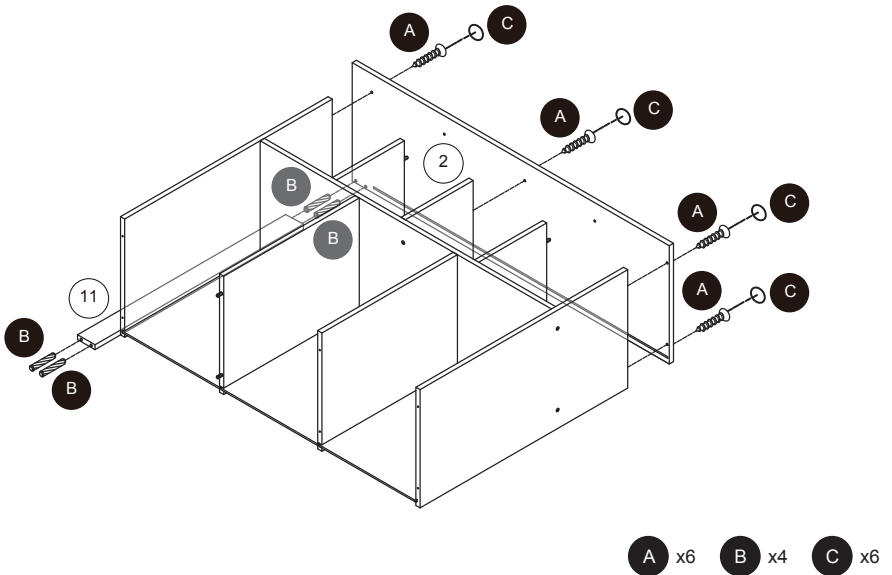

5

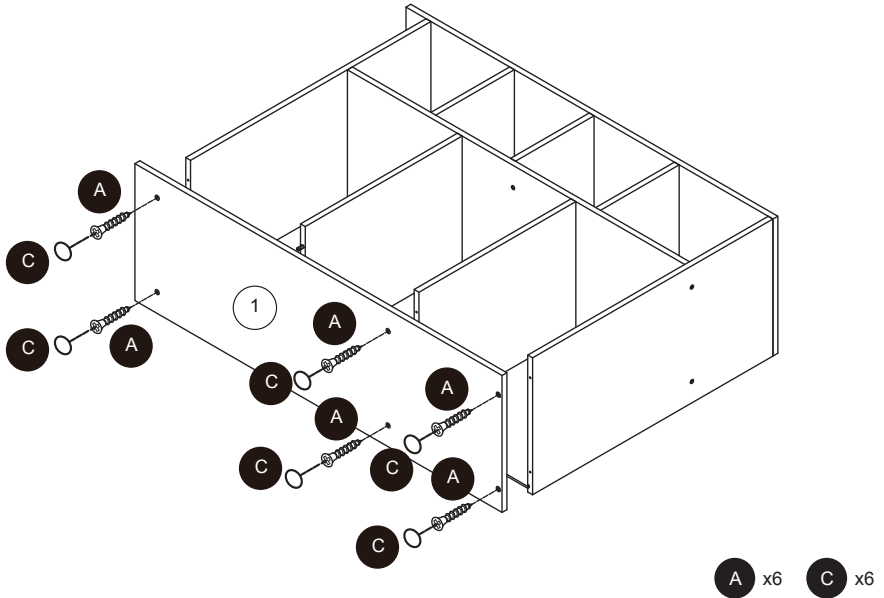

A x6 C x6

6

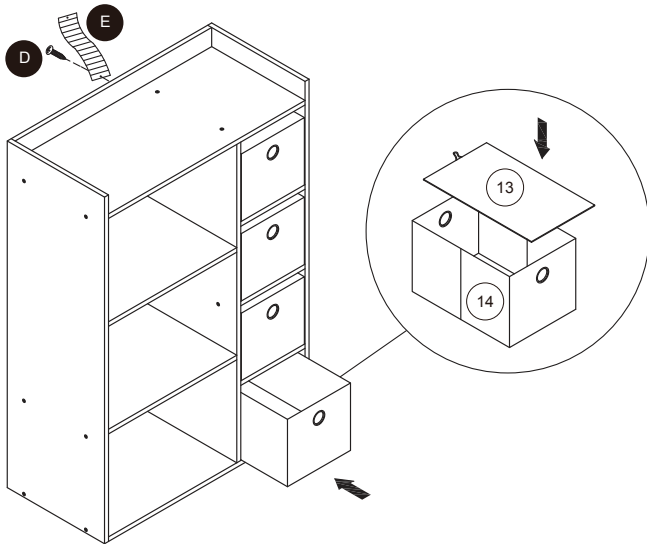

D x1 E x1

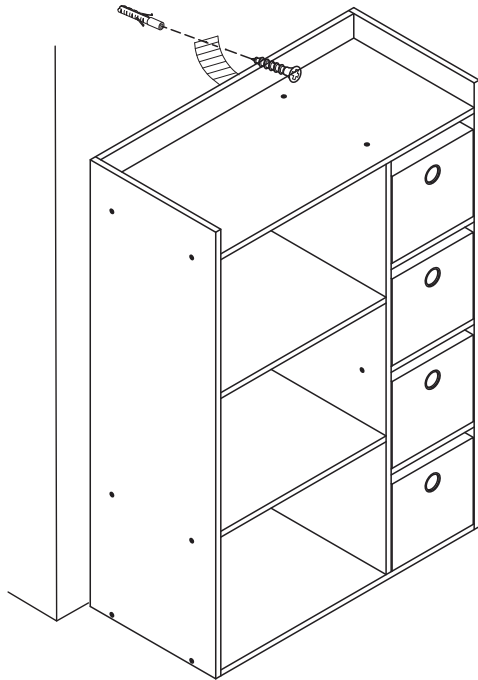
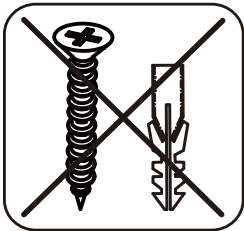

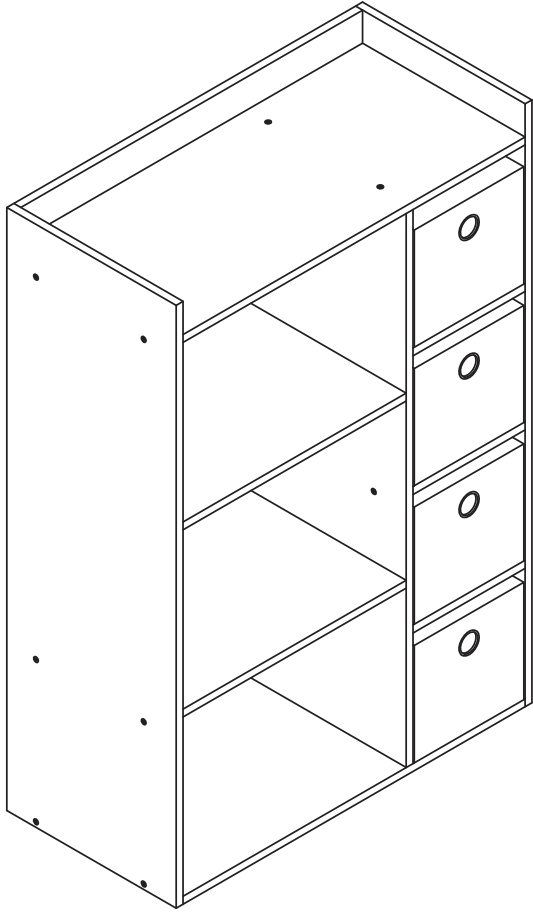

IMPORTÉ PAR WALIBUY SAS
270 avenue de l'Espace, 59118 WAMBRECHIES - FRANCE
Service après vente : **sav.alicesgarden.fr - sav.alicesgarden.be**

IMPORTADO POR WALIBUY SPAIN SL
Carrer de Mallorca 289, Entresuelo 2, 08037 BARCELONA - ESPAÑA
Servicio postventa : **alicesgarden.es/cms/contacto**

IMPORTED BY ALICE'S GARDEN UK LTD
Office G07, Dowgate Hill House, EC4R 2SU London - UNITED KINGDOM
After sales service: **alicesgarden.co.uk/cms/contact-us**

INGEVOERD DOOR WALIBUY SAS
270 avenue de l'Espace, 59118 WAMBRECHIES - FRANKRIJK
After-sales : **aftersales.alicesgarden.nl - aftersales.alicesgarden.be**

IMPORTADO PARA WALIBUY SPAIN SL
Carrer de Mallorca 289, Entresuelo 2, 08037 BARCELONA - ESPAÑA
Serviço pós-venda : **alicesgarden.pt/cms/contacto**

IMPORTATO DA WALIBUY ITALIA S.R.L
Via Torino 60, 20123 MILANO - ITALIA
Contatto : **contatto@alicesgarden.it**

IMPORTED BY ALICE'S GARDEN OUTDOOR PTY LTD
SHOP 1, 1 Denham Street Bondi 2026 NSW - AUSTRALIA
Contact : **service@alicesgarden.com.au**

IMPORTIERT VON WALIBUY SAS
270 AVENUE DE L'ESPACE, 59118 WAMBRECHIES - FRANKREICH
Kundendienst : **kundenservice@alicesgarden.de**
