

ISKACLS1

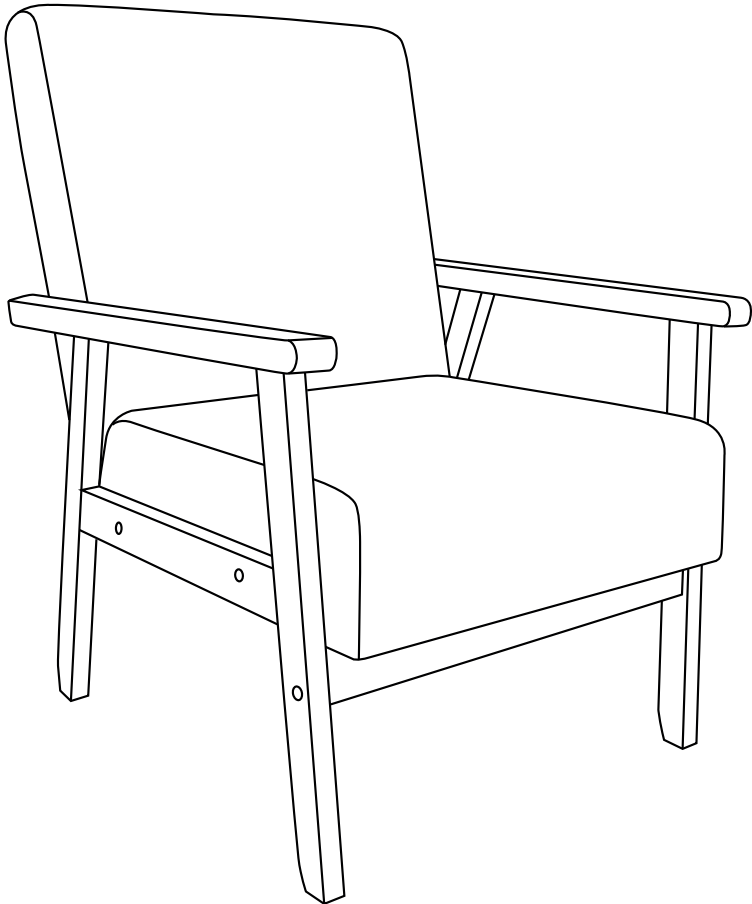

FRANÇAIS

Conseils d'entretien.....	6
Conseils d'utilisation.....	7
Garantie.....	8
Montage.....	9

**IMPORTANT, À CONSERVER
POUR CONSULTATION ULTÉRIEURE :
À LIRE ATTENTIVEMENT**

ESPAÑOL

Instrucciones de mantenimiento.....	6
Consejos de uso.....	7
Garantía.....	8
Montaje.....	9

**IMPORTANTE, CONSÉRVELO
PARA FUTURAS REFERENCIAS:
LEA ATENTAMENTE**

ENGLISH

Directions for use.....	6
Directions for use.....	7
Warranty.....	8
Assembly.....	9

**IMPORTANT, RETAIN FOR FUTURE
REFERENCE: PLEASE READ
CAREFULLY**

NEDERLANDS

Onderhoud.....	6
Gebruiksaanwijzing	7
Garantie.....	8
Montage.....	9

**BELANGRIJK, BEWAAR VOOR
TOEKOMSTIGE REFERENTIE:
ZORGVULDIG LEZEN**

PORTUGUÊS

Instruções de utilização	6
Dicas para usar	7
Garantia.....	8
Assembleia.....	9

**IMPORTANTE, CONSERVE A
REFERÊNCIA DA FATURA:
LEIA CUIDADOSAMENTE**

ITALIANO

Consigli per la manutenzione	6
Consigli per l'utilizzo	7
Garanzia.....	8
Montaggio.....	9

**IMPORTANTE, CONSERVARE PER
ULTERIORI CONSULTAZIONI:
LEGGERE ATTENTAMENTE**

DEUTSCH

Pflegehinweis	6
Verwendungstipps	7
Garantie.....	8
Montage	9

**WICHTIG, ZUM SPÄTEREN
GEBRAUCH AUFHEBEN UND
SORGFÄLTIG DURCHLESEN**



Destiné à un usage domestique
Destinado a un uso doméstico
For domestic use
Bestemd voor huishoudelijk gebruik
Para uso doméstico
Destinato ad un uso domestico
Bestimmt für den Hausgebrauch



Attention : risques de blessures
Cuidado : riesgo de lesión
Warning : risk of injuries
Waarschuwing: risico op verwondigen
Cuidado: risco de ferimentos
Attenzione : rischio infortunio
Warnung: Verletzungsgefahr



Poids maximal : 110kg
Peso máximo : 110kg
Maximum weight : 110kg
Maximale gewicht: 110kg
Peso máximo: 110kg
Peso massimo: 110kg
Maximale Belastbarkeit: 110kg

CONSEILS D'ENTRETIEN / INSTRUCCIONES DE MANTENIMIENTO / DIRECTIONS FOR MAINTENANCE / ONDERHOUD / INSTRUÇÕES PARA MANUTENÇÃO / CONSIGLI PER LA MANUTENZIONE / PFLEFEHINWELS

FR

Bois: Dépoussiérer régulièrement avec un chiffon propre, doux et sec.
Proscrire tout abrasif et produits acides. Ne jamais employer de solvants. Nettoyage professionnel uniquement.

ES

Quitar el polvo regularmente con un paño limpio, suave y seco.
No utilice productos abrasivos o ácidos. No utilice nunca disolventes de limpieza. Sólo se debe realizar una limpieza profesional.

EN

Regularly dust with a clean, soft and dry cloth.
Do not use any abrasive or acidic products. Never use cleaning solvents. Professional cleaning only.

NL

Stof regelmatig af met een schone, zachte en droge doek. Alleen
Sluit alle schurende en zure producten uit. Gebruik nooit oplosmiddelen. Alleen professionele reiniging.

PT

Pó regularmente com um espanador limpo, macio e seco.
Proibir qualquer esfregão e produtos ácidos. Nunca utilizar solvente de limpeza. Apenas limpeza profissional.

IT

Spolverare regolarmente con un panno pulito, morbido e asciutto.
Non usare prodotti abrasivi o acidi. Non usare mai solventi. Solo pulizia professionale.

DE

Regelmäßig mit einem sauberen, weichen und trockenen Tuch abstauben.
Scheuernde und säurehaltige Mittel dürfen keinesfalls angewendet werden. Verwenden Sie niemals Lösungsmittel. Nur professionelle Reinigung.

CONSEILS D'UTILISATION / INSTRUCCIONES DE USO / DIRECTIONS FOR USE / GEBRUIKSIINSTRUCTIES / INSTRUÇÕES DE UTILIZAÇÃO / CONSIGLI PER L'USO / ANWENDUNGS

FR

Ne pas monter sur la chaise / Ne pas se balancer.

Attention, ne pas s'asseoir sur les accoudoirs. En effet, cela peut entraîner une dégradation du produit, voire des blessures, n'entrant pas dans le cadre de la garantie.

ES

No se ponga de pie sobre la silla ni se columpie en ella.

No se siente en los reposabrazos. Esto puede provocar daños en el producto o incluso lesiones, que no están cubiertas por la garantía.

EN

Do not stand up on the chair and/or swing on the chair

Do not sit on the armrests. Doing so may cause damage to the product or even injury, which is not covered by the warranty.

NL

Ga niet op de stoel staan/Niet schommelen.

Ga niet op de arMLEUNINGEN zitten. Dit kan leiden tot schade aan het product of zelfs letsel, wat niet onder de garantie valt.

PT

Não se levantar sobre a cadeira e/ou balançar sobre a cadeira.

Não se sentar nos apoios de braços. Isto pode levar a danos no produto ou mesmo a ferimentos, que não estão cobertos pela garantia.

IT

Non salire sulla sedia / Non dondolare.

Non sedersi sui braccioli. Ciò può causare danni al prodotto o addirittura lesioni, che non sono coperte dalla garanzia.

DE

Nicht auf den Stuhl stellen / Nicht schaukeln.

Setzen Sie sich nicht auf die Armlehnen. Dies kann nämlich zu einer Beschädigung des Produkts oder sogar zu Verletzungen führen, die nicht unter die Garantie fallen.

GARANTIE / GARANTÍA / WARRANTY / GARANTIA / GARANZIA

FR

Alice's Garden garantit toutes les pièces du produit contre tout vice de fabrication et de matériau pendant une période de 2 ans à compter de la date de réception par le consommateur.

LISTE DES EXCLUSIONS DE GARANTIE

- Le non-respect des conseils d'utilisation du constructeur.

ES

Alice's Garden garantiza que todas las piezas del producto están libres de defectos de fabricación y materiales durante un periodo de 2 años a partir de la fecha de recepción por parte del consumidor.

LISTA DE EXCLUSIONES DE LA GARANTÍA

- No seguir las instrucciones de uso del fabricante.

EN

Alice's Garden warrants all parts of the product to be free from defects in workmanship and materials for a period of 2 years from the date of receipt by the consumer.

LIST OF WARRANTY EXCLUSIONS

- Failure to follow the manufacturer's instructions for use.

NL

Alice's Garden garandeert dat alle onderdelen van het product vrij zijn van fabricage- en materiaal-fouten gedurende een periode van 2 jaar vanaf de datum van ontvangst door de consument.

LIJST VAN GARANTIE-UITSLUITINGEN

- Het niet volgen van de gebruiksaanwijzing van de fabrikant.

PT

Alice's Garden garante que todas as partes do produto estão livres de defeitos de fabrico e materiais durante um período de 2 anos a partir da data da sua recepção pelo consumidor.

LISTA DE EXCLUSÕES DE GARANTIA

- Não seguir as instruções de utilização do fabricante.

IT

Alice's Garden garantisce che tutte le parti del prodotto sono prive di difetti di lavorazione e di materiali per un periodo di 2 anni dalla data di ricevimento da parte del consumatore.

ELENCO DELLE ESCLUSIONI DALLA GARANZIA

- Mancata osservanza delle istruzioni d'uso del produttore.

DE

Alice's Garden garantiert für einen Zeitraum von zwei Jahren ab dem Datum des Erhalts durch den Verbraucher, dass alle Teile des Produkts frei von Verarbeitungs- und Materialfehlern sind.

LISTE DER GARANTIEAUSSCHLÜSSE

- Die Nichtbeachtung der Gebrauchshinweise des Herstellers.

MONTAGE / MONTAJE / ASSEMBLY / MONTAGEM / MONTAGGIO

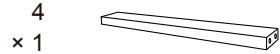
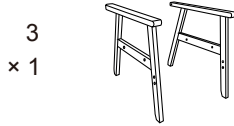
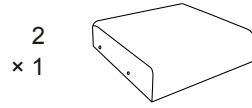
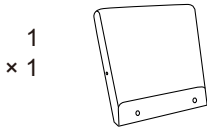

A



x 2

B



M6X50mm

x 2

C



M8x50mm

x 6

D



M8x70mm

x 2

E



M8x22mm

x 2

F



x 1

G



x 8

H



x 4

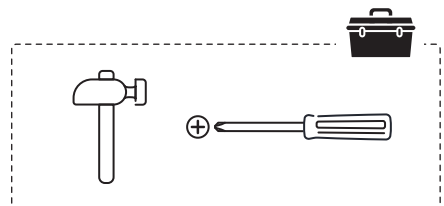

1

C x2
E x2
F x1

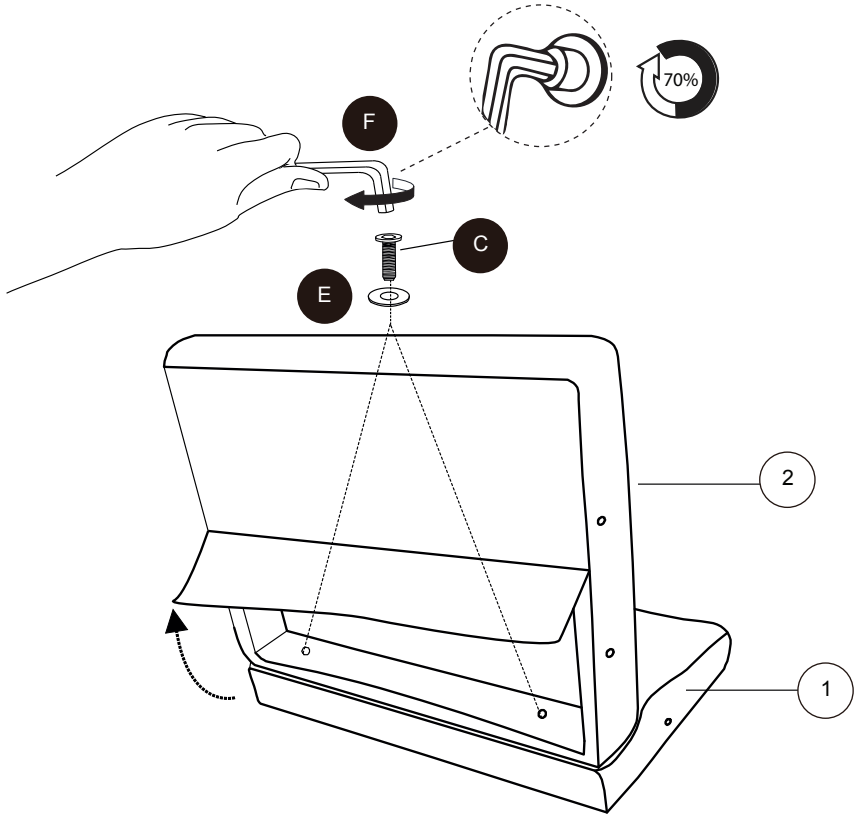

2

A x2

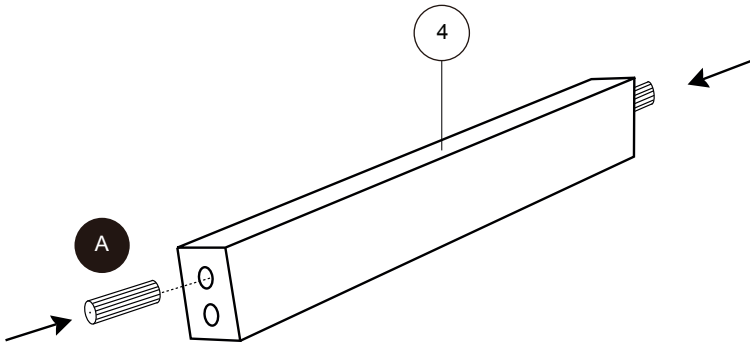

3

- B x1
- C x2
- D x1

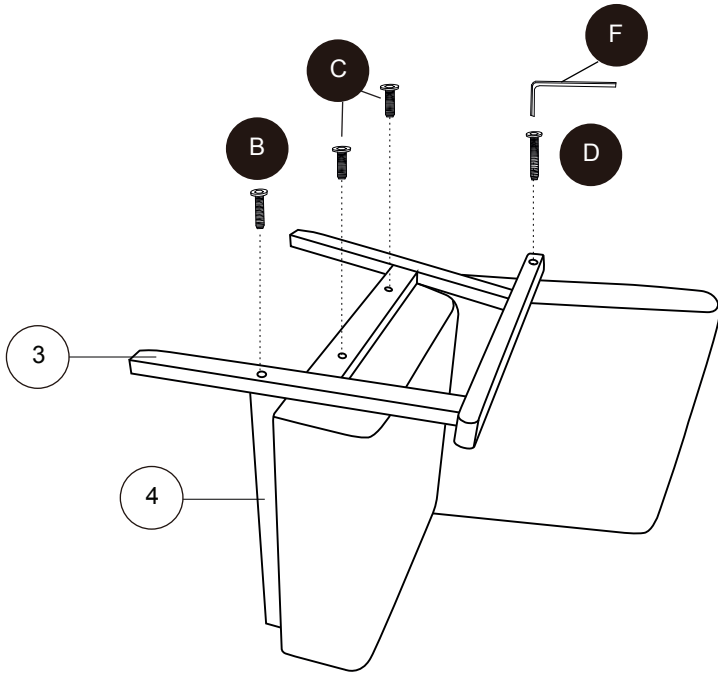

4

- B x1
- C x2
- D x1

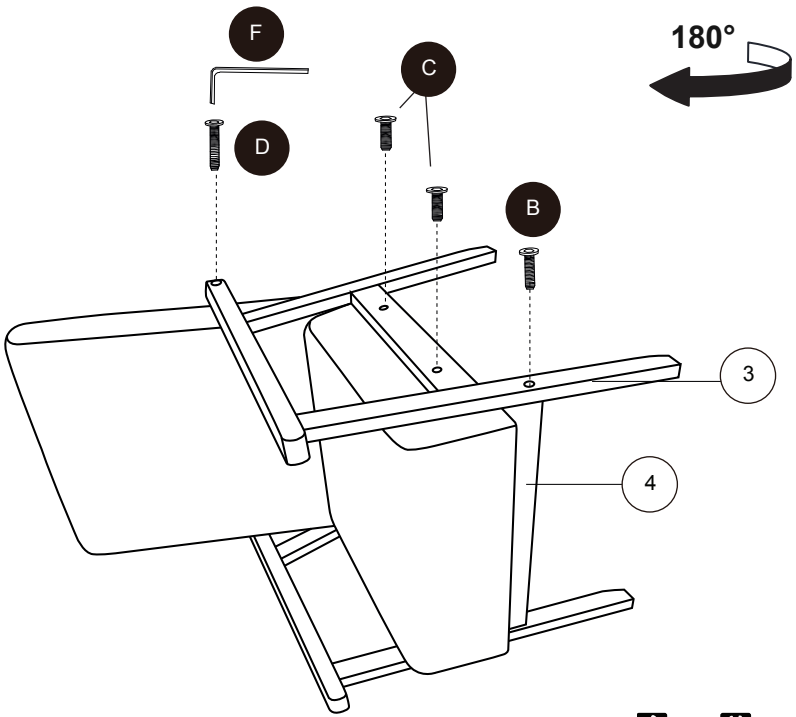

5

H x4

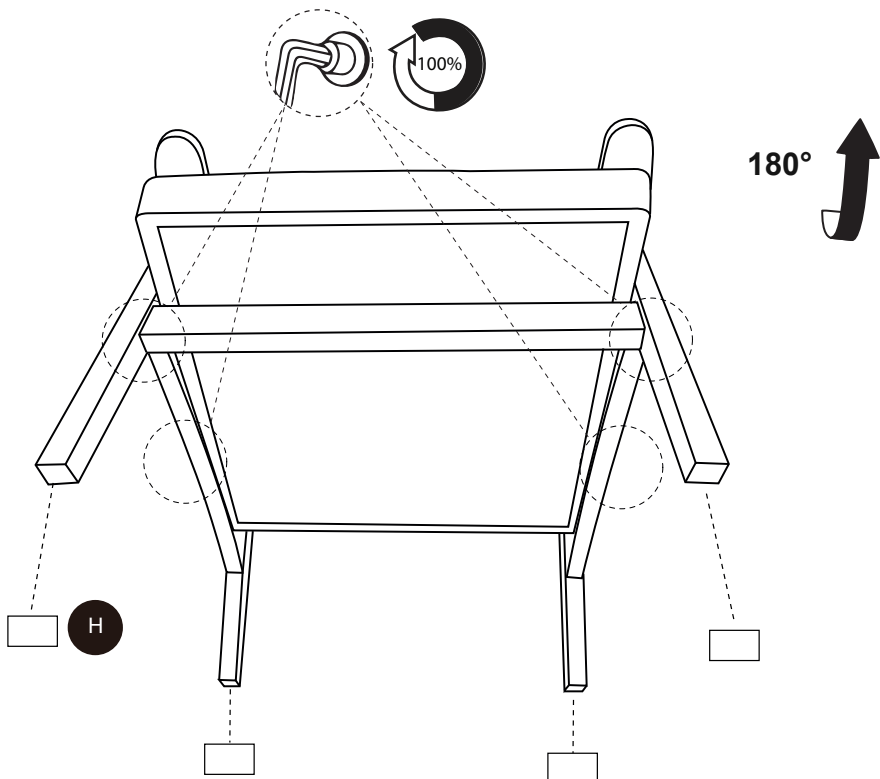

6

G x8

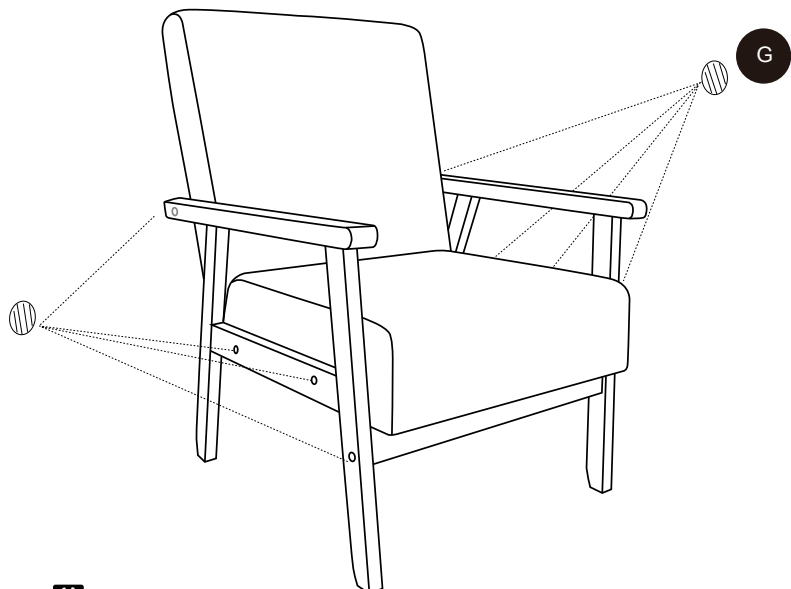

7

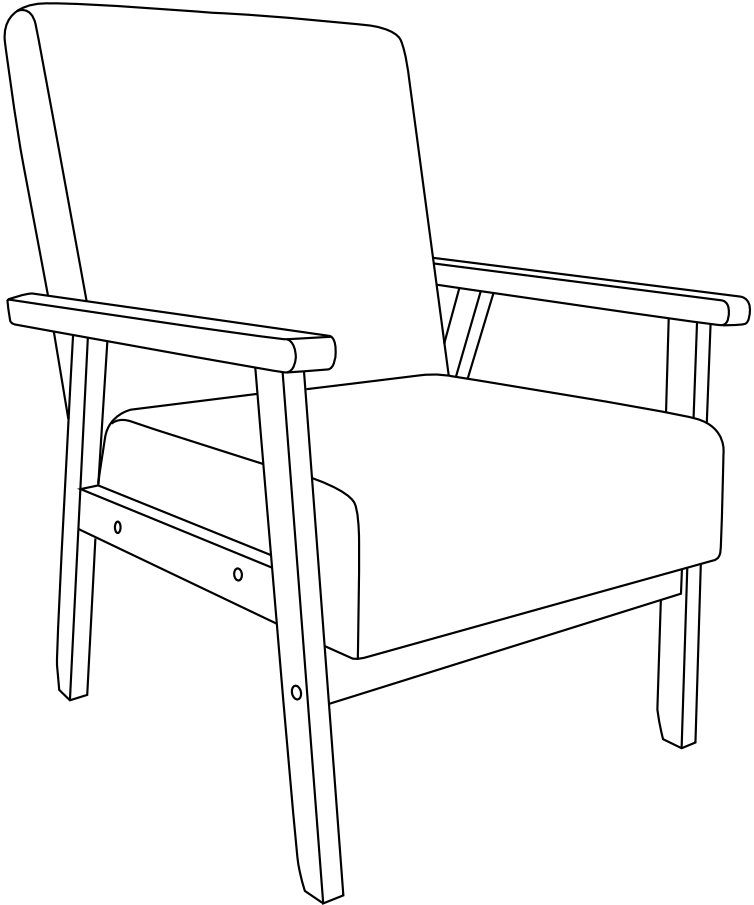

IMPORTÉ PAR WALIBUY SAS
270 avenue de l'Espace, 59118 WAMBRECHIES - FRANCE
Service après vente : sav.alicesgarden.fr - sav.alicesgarden.be

IMPORTADO POR WALIBUY SPAIN SL
Carrer de Mallorca 289, Entresuelo 2, 08037 BARCELONA - ESPAÑA
Servicio postventa : alicesgarden.es/cms/contacto

IMPORTED BY ALICE'S GARDEN UK LTD
23 Copenhagen Street, LONDON N10JB - UNITED KINGDOM
After sales service: alicesgarden.co.uk/cms/contact-us

INGEVOERD DOOR WALIBUY SAS
270 avenue de l'Espace, 59118 WAMBRECHIES - FRANKRIJK
After-sales : aftersales.alicesgarden.nl - aftersales.alicesgarden.be

IMPORTADO PARA WALIBUY SPAIN SL
Carrer de Mallorca 289, Entresuelo 2, 08037 BARCELONA - ESPAÑA
Serviço pós-venda : alicesgarden.pt/cms/contacto

IMPORTATO DA WALIBUY ITALIA S.R.L
Via Torino 60, 20123 MILANO - ITALIA
Contatto : contatto@alicesgarden.it

IMPORTED BY ALICE'S GARDEN OUTDOOR PTY LTD
135-153 New South Head Road, Edgecliff NSW 2027 - AUSTRALIA
Contact : service@alicesgarden.com.au

IMPORTIERT VON WALIBUY SAS
270 AVENUE DE L'ESPACE, 59118 WAMBRECHIES - FRANKREICH
Kundendienst : kundenservice@alicesgarden.de



FR

Donnez ou recyclez
vos meubles.



Association

ou



Magasin

ou



Déchèterie

<https://quefairedemesdechets.fr>

ISKACLS2

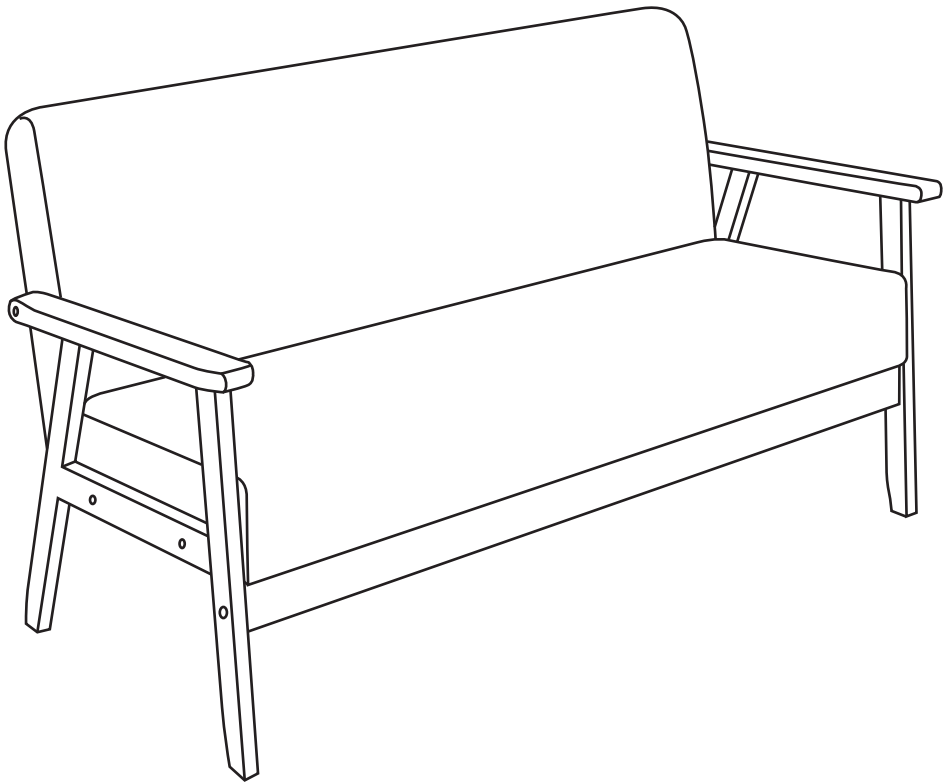

alicesgarden.fr - alicesgarden.be - alicesgarden.es - alicesgarden.nl - alicesgarden.co.uk -
alicesgarden.pt - alicesgarden.it - alicesgarden.com.au - alicesgarden.de

FRANÇAIS

Conseils d'entretien.....	6
Conseils d'utilisation.....	7
Garantie.....	8
Montage.....	9

**IMPORTANT, À CONSERVER
POUR CONSULTATION ULTÉRIEURE :
À LIRE ATTENTIVEMENT**

ESPAÑOL

Instrucciones de mantenimiento.....	6
Consejos de uso.....	7
Garantía.....	8
Montaje.....	9

**IMPORTANTE, CONSÉRVELO
PARA FUTURAS REFERENCIAS:
LEA ATENTAMENTE**

ENGLISH

Directions for use.....	6
Directions for use.....	7
Warranty.....	8
Assembly.....	9

**IMPORTANT, RETAIN FOR FUTURE
REFERENCE: PLEASE READ
CAREFULLY**

NEDERLANDS

Onderhoud.....	6
Gebruiksaanwijzing	7
Garantie.....	8
Montage.....	9

**BELANGRIJK, BEWAAR VOOR
TOEKOMSTIGE REFERENTIE:
ZORGVULDIG LEZEN**

PORTUGUÊS

Instruções de utilização	6
Dicas para usar	7
Garantia.....	8
Assembleia.....	9

**IMPORTANTE, CONSERVE A
REFERÊNCIA DA FATURA:
LEIA CUIDADOSAMENTE**

ITALIANO

Consigli per la manutenzione	6
Consigli per l'utilizzo	7
Garanzia.....	8
Montaggio.....	9

**IMPORTANTE, CONSERVARE PER
ULTERIORI CONSULTAZIONI:
LEGGERE ATTENTAMENTE**

DEUTSCH

Pflegehinweis	6
Verwendungstipps	7
Garantie.....	8
Montage	9

**WICHTIG, ZUM SPÄTEREN
GEBRAUCH AUFHEBEN UND
SORGFÄLTIG DURCHLESEN**



Destiné à un usage domestique
Destinado a un uso doméstico
For domestic use
Bestemd voor huishoudelijk gebruik
Para uso doméstico
Destinato ad un uso domestico
Bestimmt für den Hausgebrauch



Attention : risques de blessures
Cuidado : riesgo de lesión
Warning : risk of injuries
Waarschuwing: risico op verwondigen
Cuidado: risco de ferimentos
Attenzione : rischio infortunio
Warnung: Verletzungsgefahr



Poids maximal : 110kg
Peso máximo : 110kg
Maximum weight : 110kg
Maximale gewicht: 110kg
Peso máximo: 110kg
Peso massimo: 110kg
Maximale Belastbarkeit: 110kg

CONSEILS D'ENTRETIEN / INSTRUCCIONES DE MANTENIMIENTO / DIRECTIONS FOR MAINTENANCE / ONDERHOUD / INSTRUÇÕES PARA MANUTENÇÃO / CONSIGLI PER LA MANUTENZIONE / PFLEFEHINWELS

FR

Bois: Dépoussiérer régulièrement avec un chiffon propre, doux et sec.
Proscrire tout abrasif et produits acides. Ne jamais employer de solvants. Nettoyage professionnel uniquement.

ES

Quitar el polvo regularmente con un paño limpio, suave y seco.
No utilice productos abrasivos o ácidos. No utilice nunca disolventes de limpieza. Sólo se debe realizar una limpieza profesional.

EN

Regularly dust with a clean, soft and dry cloth.
Do not use any abrasive or acidic products. Never use cleaning solvents. Professional cleaning only.

NL

Stof regelmatig af met een schone, zachte en droge doek. Alleen
Sluit alle schurende en zure producten uit. Gebruik nooit oplosmiddelen. Alleen professionele reiniging.

PT

Pó regularmente com um espanador limpo, macio e seco.
Proibir qualquer esfregão e produtos ácidos. Nunca utilizar solvente de limpeza. Apenas limpeza profissional.

IT

Spolverare regolarmente con un panno pulito, morbido e asciutto.
Non usare prodotti abrasivi o acidi. Non usare mai solventi. Solo pulizia professionale.

DE

Regelmäßig mit einem sauberen, weichen und trockenen Tuch abstauben.
Scheuernde und säurehaltige Mittel dürfen keinesfalls angewendet werden. Verwenden Sie niemals Lösungsmittel. Nur professionelle Reinigung.

CONSEILS D'UTILISATION / INSTRUCCIONES DE USO / DIRECTIONS FOR USE / GEBRUIKSIINSTRUCTIES / INSTRUÇÕES DE UTILIZAÇÃO / CONSIGLI PER L'USO / ANWENDUNGS

FR

Ne pas monter sur la chaise / Ne pas se balancer.

Attention, ne pas s'asseoir sur les accoudoirs. En effet, cela peut entraîner une dégradation du produit, voire des blessures, n'entrant pas dans le cadre de la garantie.

ES

No se ponga de pie sobre la silla ni se columpie en ella.

No se siente en los reposabrazos. Esto puede provocar daños en el producto o incluso lesiones, que no están cubiertas por la garantía.

EN

Do not stand up on the chair and/or swing on the chair

Do not sit on the armrests. Doing so may cause damage to the product or even injury, which is not covered by the warranty.

NL

Ga niet op de stoel staan/Niet schommelen.

Ga niet op de arMLEUNINGEN zitten. Dit kan leiden tot schade aan het product of zelfs letsel, wat niet onder de garantie valt.

PT

Não se levantar sobre a cadeira e/ou balançar sobre a cadeira.

Não se sentar nos apoios de braços. Isto pode levar a danos no produto ou mesmo a ferimentos, que não estão cobertos pela garantia.

IT

Non salire sulla sedia / Non dondolare.

Non sedersi sui braccioli. Ciò può causare danni al prodotto o addirittura lesioni, che non sono coperte dalla garanzia.

DE

Nicht auf den Stuhl stellen / Nicht schaukeln.

Setzen Sie sich nicht auf die Armlehnen. Dies kann nämlich zu einer Beschädigung des Produkts oder sogar zu Verletzungen führen, die nicht unter die Garantie fallen.

GARANTIE / GARANTÍA / WARRANTY / GARANTIA / GARANZIA

FR

Alice's Garden garantit toutes les pièces du produit contre tout vice de fabrication et de matériau pendant une période de 2 ans à compter de la date de réception par le consommateur.

LISTE DES EXCLUSIONS DE GARANTIE

- Le non-respect des conseils d'utilisation du constructeur.

ES

Alice's Garden garantiza que todas las piezas del producto están libres de defectos de fabricación y materiales durante un periodo de 2 años a partir de la fecha de recepción por parte del consumidor.

LISTA DE EXCLUSIONES DE LA GARANTÍA

- No seguir las instrucciones de uso del fabricante.

EN

Alice's Garden warrants all parts of the product to be free from defects in workmanship and materials for a period of 2 years from the date of receipt by the consumer.

LIST OF WARRANTY EXCLUSIONS

- Failure to follow the manufacturer's instructions for use.

NL

Alice's Garden garandeert dat alle onderdelen van het product vrij zijn van fabricage- en materiaalfouten gedurende een periode van 2 jaar vanaf de datum van ontvangst door de consument.

LIJST VAN GARANTIE-UITSLUITINGEN

- Het niet volgen van de gebruiksaanwijzing van de fabrikant.

PT

Alice's Garden garante que todas as partes do produto estão livres de defeitos de fabrico e materiais durante um período de 2 anos a partir da data da sua recepção pelo consumidor.

LISTA DE EXCLUSÕES DE GARANTIA

- Não seguir as instruções de utilização do fabricante.

IT

Alice's Garden garantisce che tutte le parti del prodotto sono prive di difetti di lavorazione e di materiali per un periodo di 2 anni dalla data di ricevimento da parte del consumatore.

ELENCO DELLE ESCLUSIONI DALLA GARANZIA

- Mancata osservanza delle istruzioni d'uso del produttore.

DE

Alice's Garden garantiert für einen Zeitraum von zwei Jahren ab dem Datum des Erhalts durch den Verbraucher, dass alle Teile des Produkts frei von Verarbeitungs- und Materialfehlern sind.

LISTE DER GARANTIEAUSSCHLÜSSE

- Die Nichtbeachtung der Gebrauchshinweise des Herstellers.

MONTAGE / MONTAJE / ASSEMBLY / MONTAGEM / MONTAGGIO

1
x 1

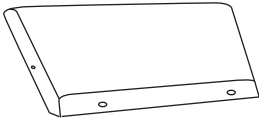

2
x 1

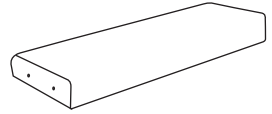

3
x 1



4
x 1



A



x 2

B



M6X50mm

x 2

C



M8x50mm

x 6

D



M8x70mm

x 2

E



M8x22mm

x 2

F



x 1

G



x 8

H



x 4

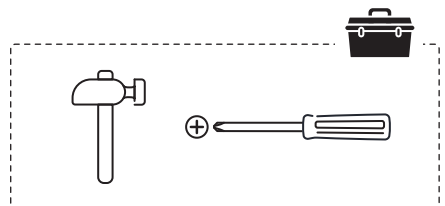

1

C x2
E x2
F x1

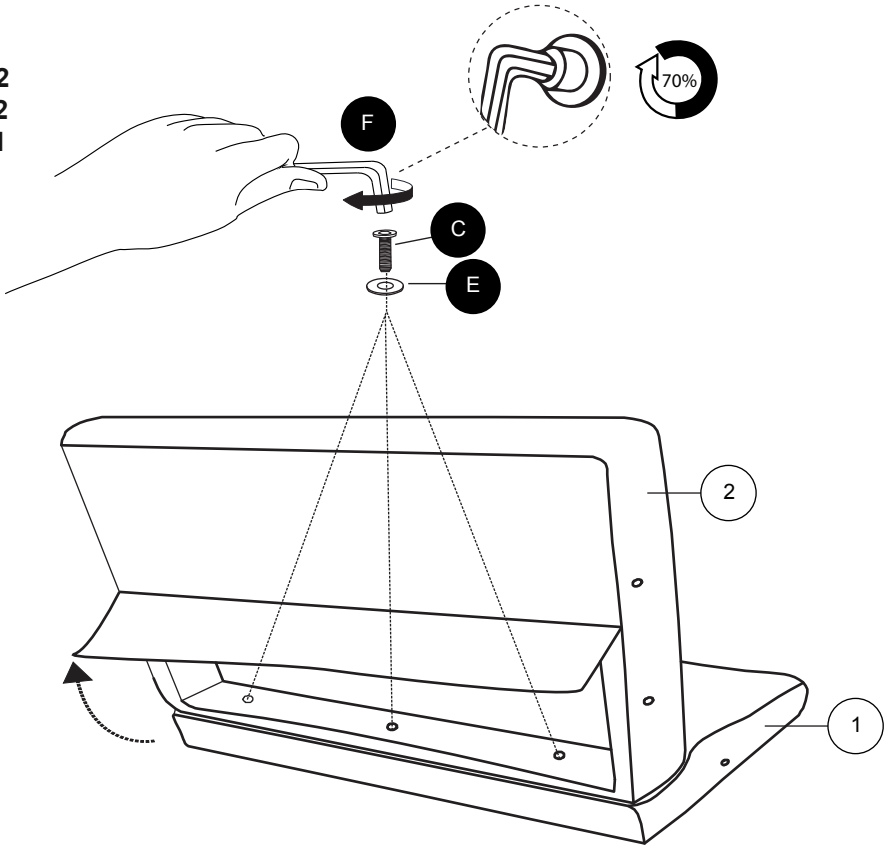

2

A x2

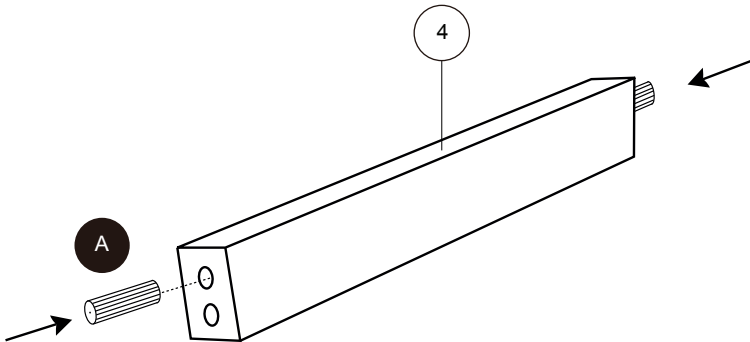

3

- B x1
- C x2
- D x1

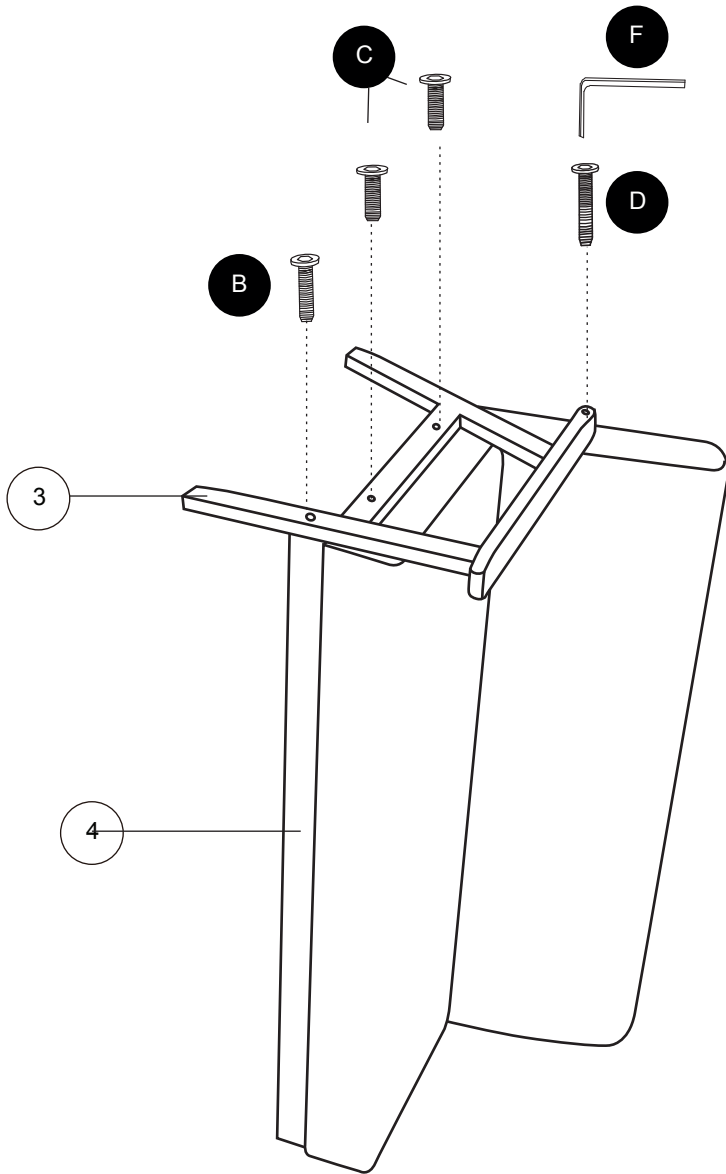

4

- B x1
- C x2
- D x1

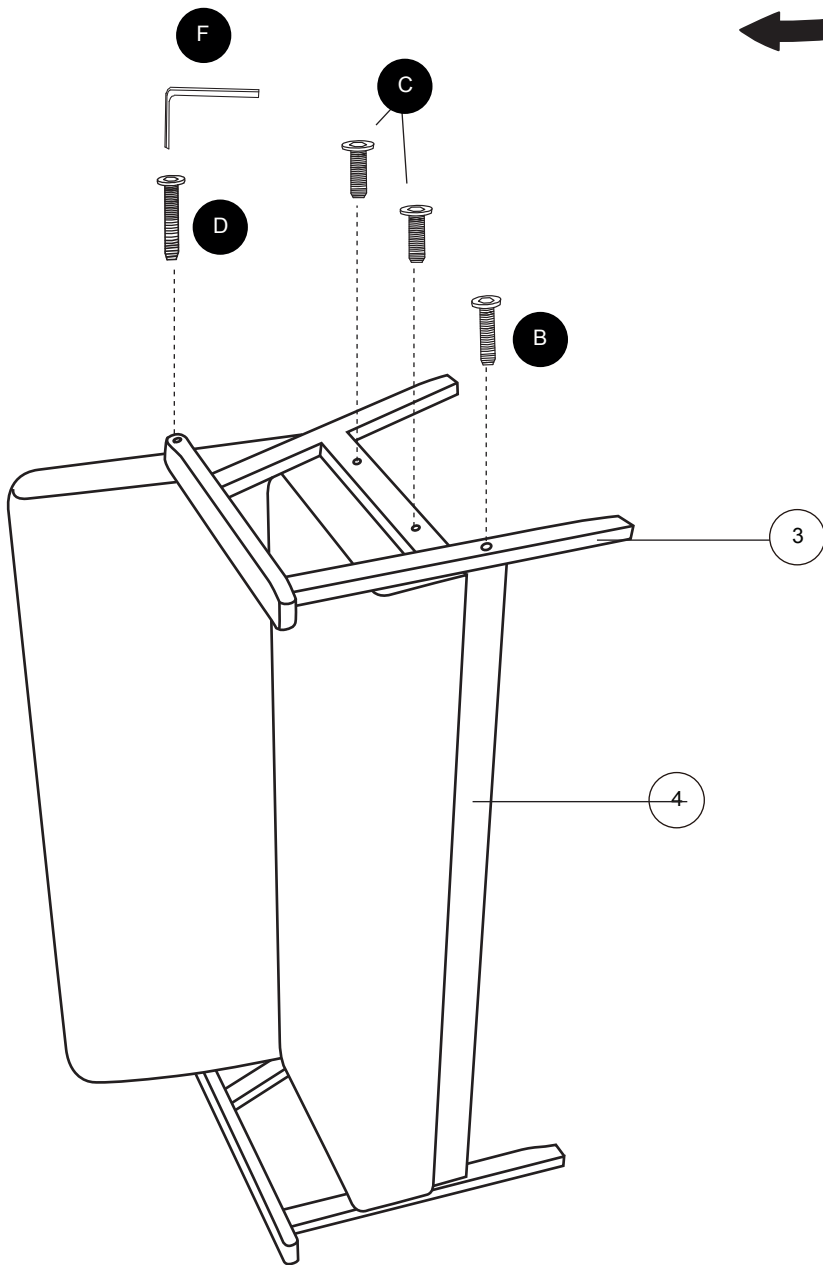

5

H x4

180° 

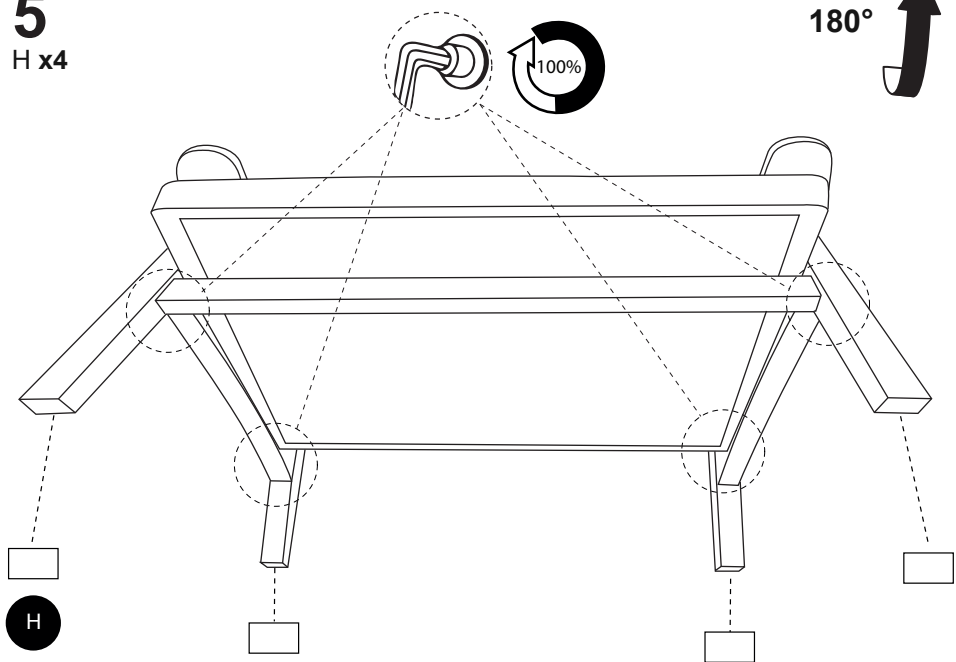

6

G x8

G 

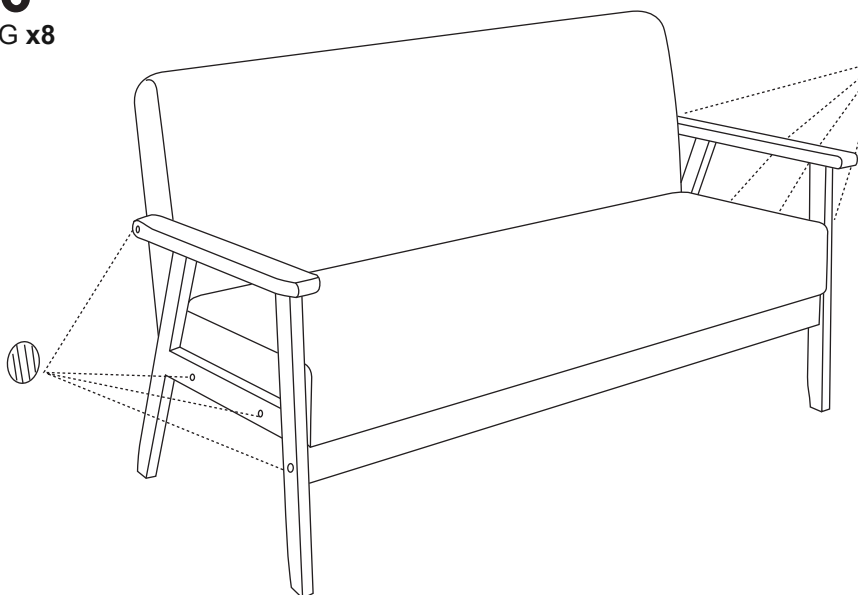

7

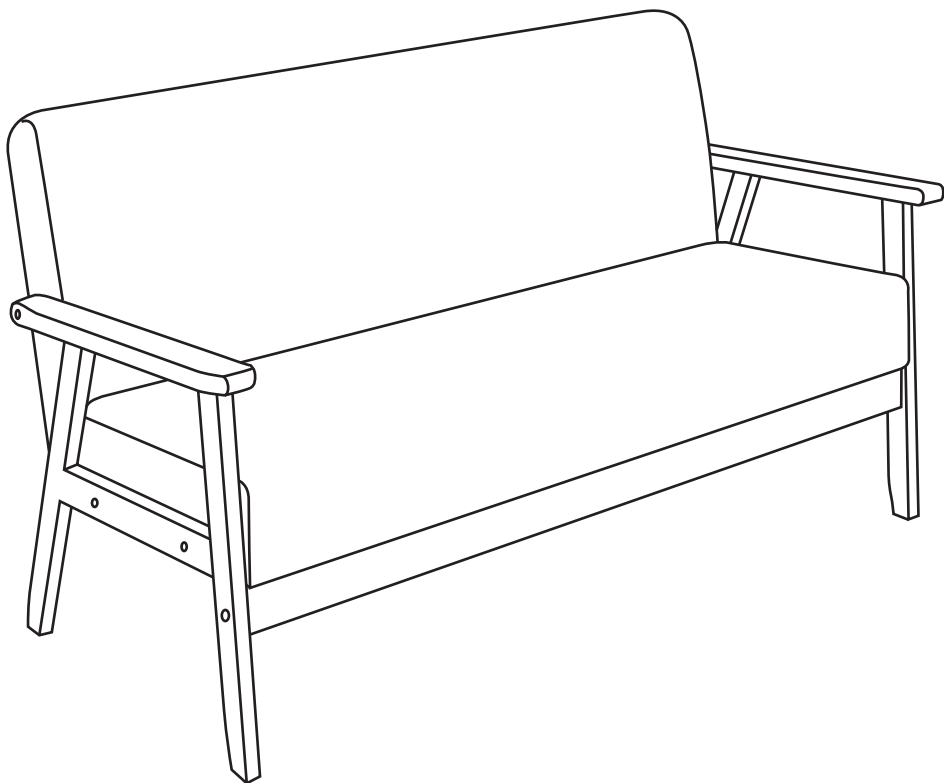

IMPORTÉ PAR WALIBUY SAS
270 avenue de l'Espace, 59118 WAMBRECHIES - FRANCE
Service après vente : sav.alicesgarden.fr - sav.alicesgarden.be

IMPORTADO POR WALIBUY SPAIN SL
Carrer de Mallorca 289, Entresuelo 2, 08037 BARCELONA - ESPAÑA
Servicio postventa : alicesgarden.es/cms/contacto

IMPORTED BY ALICE'S GARDEN UK LTD
23 Copenhagen Street, LONDON N10JB - UNITED KINGDOM
After sales service: alicesgarden.co.uk/cms/contact-us

INGEVOERD DOOR WALIBUY SAS
270 avenue de l'Espace, 59118 WAMBRECHIES - FRANKRIJK
After-sales : aftersales.alicesgarden.nl - aftersales.alicesgarden.be

IMPORTADO PARA WALIBUY SPAIN SL
Carrer de Mallorca 289, Entresuelo 2, 08037 BARCELONA - ESPAÑA
Serviço pós-venda : alicesgarden.pt/cms/contacto

IMPORTATO DA WALIBUY ITALIA S.R.L
Via Torino 60, 20123 MILANO - ITALIA
Contatto : contatto@alicesgarden.it

IMPORTED BY ALICE'S GARDEN OUTDOOR PTY LTD
135-153 New South Head Road, Edgecliff NSW 2027 - AUSTRALIA
Contact : service@alicesgarden.com.au

IMPORTIERT VON WALIBUY SAS
270 AVENUE DE L'ESPACE, 59118 WAMBRECHIES - FRANKREICH
Kundendienst : kundenservice@alicesgarden.de



FR

Donnez ou recyclez
vos meubles.



Association

ou



Magasin

ou



Déchèterie

<https://quefairedemesdechets.fr>